

# JVC

# SERVICE MANUAL

## COLOR TELEVISION

**C-20210***/S*  
**AV-20220***/S*  
**AV-20221***/S*

BASIC CHASSIS

FV4

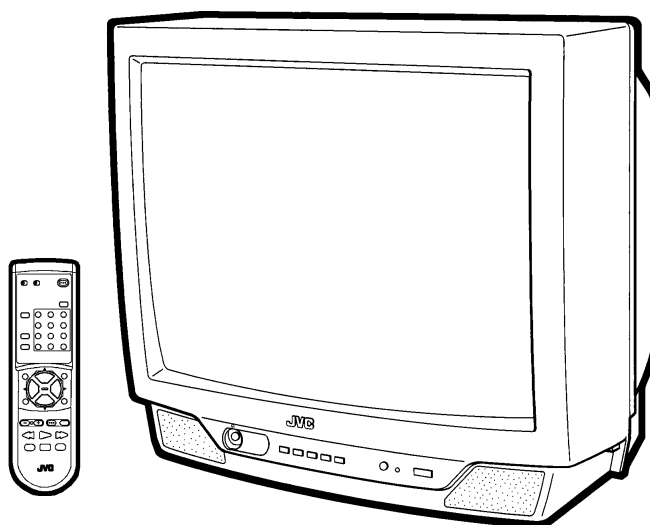

## CONTENTS

■ SPECIFICATIONS .....	2
■ SAFETY PRECAUTIONS .....	3
■ FEATURES .....	4
■ MAIN DIFFERENCE LIST .....	4
■ SPECIFIC SERVICE INSTRUCTIONS .....	5
■ SERVICE ADJUSTMENTS .....	10
■ PARTS LIST .....	25
★ OPERATING INSTRUCTIONS	
★ STANDARD CIRCUIT DIAGRAM .....	2-1

# SPECIFICATIONS

Items	Content		
	C-20210/s	AV-20220/s	AV-20221/s
<b>Dimensions (W × H × D)</b>	19-7/8" × 17-7/8" × 19-1/2" / 50.3cm × 45.2cm × 49.3cm		
<b>Mass</b>	43.2 lbs / 19.6 kg	43.8 lbs / 19.9 kg	
<b>TV RF System</b>	CCIR(M)		
<b>Color Sound System</b>	NTSC system	NTSC, BTSC System (Multi Channel Sound)	
<b>TV Receiving Channels and Frequency</b>			
<b>VL Band</b>	(02~06) 54MHz~88MHz		
<b>VH Band</b>	(07~13) 174MHz~216MHz		
<b>UHF Band</b>	(14~69) 470MHz~806MHz		
<b>CATV Receiving Channels and Frequency</b>			
<b>Low Band</b>	(02~06, A-8) by (02~06&01)	} (54MHz~804MHz)	
<b>High Band</b>	(07~13) by (07~13)		
<b>Mid Band</b>	(A~1) by (14~22)		
<b>Super Band</b>	(J~W) by (23~36)		
<b>Hyper Band</b>	(W+1~W+28) by (37~64)		
<b>Ultra Band</b>	(W+29~W+84) by (65~125)		
<b>Sub Mid Band</b>	(A8, A4~A1) by (01, 96~99)		
<b>TV/CATV Total Channel</b>	180 Channels		
<b>Intermediate Frequency</b>			
<b>Video IF Carrier</b>	45.75MHz		
<b>Sound IF Carrier</b>	41.25MHz (4.5MHz)		
<b>Color Sub Carrier</b>	3.58MHz		
<b>Power Input</b>	120V AC, 60Hz		
<b>Power Consumption</b>	87W (US) / 1.4A (CA)		
<b>Picture Tube</b>	20" (51cm) Measured Diagonally		
<b>High Voltage</b>	26.5kV ± 1kV (at zero beam current)		
<b>Speaker</b>	2" × 3-1/2" / 5 × 9cm Oval type × 1	2" × 3-1/2" / 5 × 9cm Oval type × 2	
<b>Audio Power Output</b>	1W		
<b>Input</b>			
<b>Video Input</b>	1Vp-p, 75 Ω (RCA pin jack)		
<b>Audio Input</b>	500mVrms ( -4dBs ), High Impedance (RCA pin jack)		
<b>Variable Audio Output</b>	<div style="display: flex; align-items: center;"> <div style="flex: 1; border-bottom: 1px solid black; margin-right: 10px;"></div> <div style="flex: 2;">           More then 0~1550mVrms(+6dBs)            Low impedance (400Hz when modulated 100%)            (RCA pin jack)         </div> </div>		
<b>Headphone Jack</b>	3.5mm stereo mini jack (Sound is monaural)	3.5mm stereo mini jack (Sound is stereo)	
<b>Antenna Terminal</b>	75(VHF/UHF) Terminal, F-Type Connector		
<b>Remote Control Unit</b>	RM-C306-1A (AA/R6/UM-3 battery × 2)	RM-C307-1A (AA/R6/UM-3 battery × 2)	RM-C307W-1A (AA/R6/UM-3 battery × 2)

*Design & specifications are subject to change without notice.*

# SAFETY PRECAUTIONS

- The design of this product contains special hardware, many circuits and components specially for safety purposes. For continued protection, no changes should be made to the original design unless authorized in writing by the manufacturer. Replacement parts must be identical to those used in the original circuits. Service should be performed by qualified personnel only.
- Alterations of the design or circuitry of the products should not be made. Any design alterations or additions will void the manufacturer's warranty and will further relieve the manufacturer of responsibility for personal injury or property damage resulting therefrom.
- Many electrical and mechanical parts in the products have special safety-related characteristics. These characteristics are often not evident from visual inspection nor can the protection afforded by them necessarily be obtained by using replacement components rated for higher voltage, wattage, etc. Replacement parts which have these special safety characteristics are identified in the parts list of Service manual. **Electrical components having such features are identified by shading on the schematics and by ( $\Delta$ ) on the parts list in Service manual.** The use of a substitute replacement which does not have the same safety characteristics as the recommended replacement part shown in the parts list of Service manual may cause shock, fire, or other hazards.
- Use isolation transformer when hot chassis.**  
The chassis and any sub-chassis contained in some products are connected to one side of the AC power line. An isolation transformer of adequate capacity should be inserted between the product and the AC power supply point while performing any service on some products when the HOT chassis is exposed.
- Don't short between the LIVE side ground and ISOLATED (NEUTRAL) side ground or EARTH side ground when repairing.**  
Some model's power circuit is partly different in the GND. The difference of the GND is shown by the LIVE : ( $\perp$ ) side GND, the ISOLATED(NEUTRAL) : ( $\text{↯}$ ) side GND and EARTH : ( $\oplus$ ) side GND. Don't short between the LIVE side GND and ISOLATED(NEUTRAL) side GND or EARTH side GND and never measure with a measuring apparatus (oscilloscope etc.) the LIVE side GND and ISOLATED(NEUTRAL) side GND or EARTH side GND at the same time.  
If above note will not be kept, a fuse or any parts will be broken.
- If any repair has been made to the chassis, it is recommended that the B1 setting should be checked or adjusted (See ADJUSTMENT OF B1 POWER SUPPLY).
- The high voltage applied to the picture tube must conform with that specified in Service manual. Excessive high voltage can cause an increase in X-Ray emission, arcing and possible component damage, therefore operation under excessive high voltage conditions should be kept to a minimum, or should be prevented. If severe arcing occurs, remove the AC power immediately and determine the cause by visual inspection (incorrect installation, cracked or melted high voltage harness, poor soldering, etc.). To maintain the proper minimum level of soft X-Ray emission, components in the high voltage circuitry including the picture tube must be the exact replacements or alternatives approved by the manufacturer of the complete product.
- Do not check high voltage by drawing an arc. Use a high voltage meter or a high voltage probe with a VTVM. Discharge the picture tube before attempting meter connection, by connecting a clip lead to the ground frame and connecting the other end of the lead through a 10k $\Omega$  2W resistor to the anode button.
- When service is required, observe the original lead dress. Extra precaution should be given to assure correct lead dress in the high voltage circuit area. Where a short circuit has occurred, those components that indicate evidence of overheating should be replaced. Always use the manufacturer's replacement components.

## 10. Isolation Check

### (Safety for Electrical Shock Hazard)

After re-assembling the product, always perform an isolation check on the exposed metal parts of the cabinet (antenna terminals, video/audio input and output terminals, Control knobs, metal cabinet, screwheads, earphone jack, control shafts, etc.) to be sure the product is safe to operate without danger of electrical shock.

#### (1) Dielectric Strength Test

The isolation between the AC primary circuit and all metal parts exposed to the user, particularly any exposed metal part having a return path to the chassis should withstand a voltage of 1100V AC (r.m.s.) for a period of one second.

(. . . Withstand a voltage of 1100V AC (r.m.s.) to an appliance rated up to 120V, and 3000V AC (r.m.s.) to an appliance rated 200V or more, for a period of one second.)

This method of test requires a test equipment not generally found in the service trade.

#### (2) Leakage Current Check

Plug the AC line cord directly into the AC outlet (do not use a line isolation transformer during this check.). Using a "Leakage Current Tester", measure the leakage current from each exposed metal part of the cabinet, particularly any exposed metal part having a return path to the chassis, to a known good earth ground (water pipe, etc.). Any leakage current must not exceed 0.5mA AC (r.m.s.).

However, in tropical area, this must not exceed 0.2mA AC (r.m.s.).

#### ● Alternate Check Method

Plug the AC line cord directly into the AC outlet (do not use a line isolation transformer during this check.). Use an AC voltmeter having 1000 ohms per volt or more sensitivity in the following manner. Connect a 1500 $\Omega$  10W resistor paralleled by a 0.15 $\mu$ F AC-type capacitor between an exposed metal part and a known good earth ground (water pipe, etc.). Measure the AC voltage across the resistor with the AC voltmeter. Move the resistor connection to each exposed metal part, particularly any exposed metal part having a return path to the chassis, and measure the AC voltage across the resistor. Now, reverse the plug in the AC outlet and repeat each measurement. Any voltage measured must not exceed 0.75V AC (r.m.s.). This corresponds to 0.5mA AC (r.m.s.). However, in tropical area, this must not exceed 0.3V AC (r.m.s.). This corresponds to 0.2mA AC (r.m.s.).

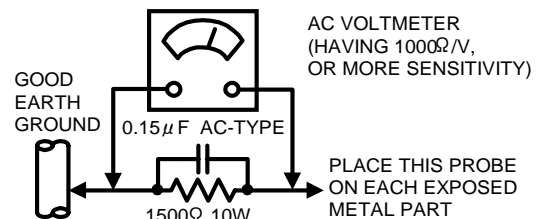

## 11. High voltage hold down circuit check.

After repair of the high voltage hold down circuit, this circuit shall be checked to operate correctly.

See item "How to check the high voltage hold down circuit".

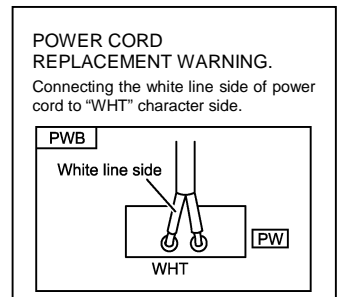
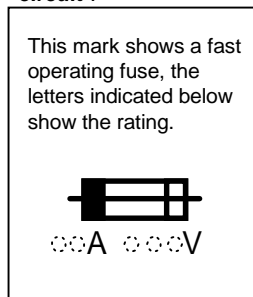

C-20210  
 AV-20220  
 AV-20221

# FEATURES

- New chassis design enables use of a single board with simplified circuitry.
- Provided with miniature tuner (TV/CATV).
- Multifunctional remote control permits picture adjustment.
- Adoption of the CHANNEL GUARD function prevents the specific channels from being selected, unless the "ID number" is key in.
- I<sup>2</sup>C bus control utilizes single chip ICs.
- Adoption of the VIDEO STATUS function.
- Adoption of the ON/OFF TIMER function.
- With 75 Ω V/U in common (F-Type) ANT Terminal.
- SLEEP TIMER for setting in real time.
- Closed-caption broadcasts can be viewed.
- Audio Video input terminal.
- Variable Audio output terminal. (AV-20220/AV-20221)
- Built-in MTS system. (AV-20220/AV-20221)

# MAIN DIFFERENCE LIST

[AV-20220/s / AV-20221/s]

△	Parts Name	Model	Charcoal model	White model
			AV-20220/s	AV-20221/s
	MAIN PWB		SFV-1063A-M2	SFV-1064A-M2
△	POWER CORD		QMPD200-200-JC (Within MAIN PWB)	QMPD209-200-JC (Within MAIN PWB)
△	FRONT CABINET		LC10109-016A-A	LC10109-017A-A
	POWER KNOB		LC30376-001A-A	LC30376-002A-A
	PUSH KNOB		LC30271-001A-A	LC30271-002A-A
△	REAR COVER		LC10108-001E-A	LC10108-003D-A
△	POWER CORD CLAMP		LC20106-001D-A	LC20106-002C-A
	REMOTE CONTROL UNIT		RM-C307-1A	RM-C307W-1A

# SPECIFIC SERVICE INSTRUCTIONS

## REPLACEMENT OF CHIP COMPONENT

### ■ CAUTIONS

1. Avoid heating for more than 3 seconds.
2. Do not rub the electrodes and the resist parts of the pattern.
3. When removing a chip part, melt the solder adequately.
4. Do not reuse a chip part after removing it.

### ■ SOLDERING IRON

1. Use a high insulation soldering iron with a thin pointed end of it.
2. A 30w soldering iron is recommended for easily removing parts.

### ■ REPLACEMENT STEPS

#### 1. How to remove Chip parts

##### ◆ Resistors, capacitors, etc.

- (1) As shown in the figure, push the part with tweezers and alternately melt the solder at each end.

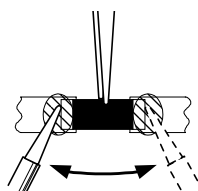

- (2) Shift with tweezers and remove the chip part.

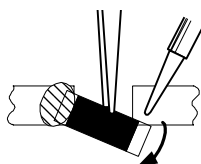

##### ◆ Transistors, diodes, variable resistors, etc.

- (1) Apply extra solder to each lead.

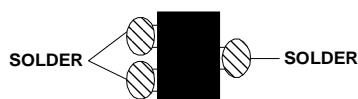

- (2) As shown in the figure, push the part with tweezers and alternately melt the solder at each lead. Shift and remove the chip part.

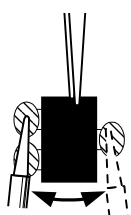

Note : After removing the part, remove remaining solder from the pattern.

#### 2. How to install Chip parts

##### ◆ Resistors, capacitors, etc.

- (1) Apply solder to the pattern as indicated in the figure.

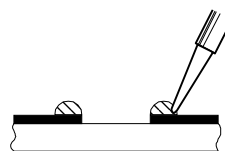

- (2) Grasp the chip part with tweezers and place it on the solder. Then heat and melt the solder at both ends of the chip part.

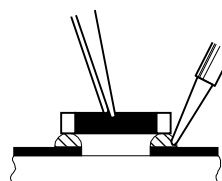

##### ◆ Transistors, diodes, variable resistors, etc.

- (1) Apply solder to the pattern as indicated in the figure.
- (2) Grasp the chip part with tweezers and place it on the solder.
- (3) First solder lead **A** as indicated in the figure.

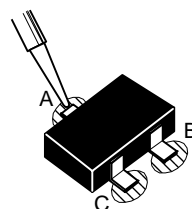

- (4) Then solder leads **B** and **C**.

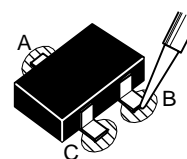

C-20210  
AV-20220  
AV-20221

## DISASSEMBLY PROCEDURE

### REMOVING THE REAR COVER

1. Unplug the power supply cord.

#### [For C-20210]

2. Remove the 5 screws marked **(A)** and a screw marked **(B)** as shown in Fig.1.

#### [For AV-20220/AV-20221]

2. Remove the 5 screws marked **(A)** and 2 screws marked **(B)** as shown in Fig.1.
3. Withdraw the REAR COVER toward you.

#### [CAUTION]

- When reinstalling the rear cover, carefully push it inward after inserting the MAIN PWB into the rear cover groove.

### REMOVING THE MAIN PW BOARD

- After removing the rear cover.
1. Pick this side of the MAIN PWB and raise one slightly, take off the PWB stopper marked **(C)** from the cabinet bottom.
  2. Pull out the MAIN PWB as it is.  
(If necessary, take off the wire clamp and connectors, etc.)

### REMOVING THE SPEAKER

- After removing the MAIN PW board.

1. Remove the 2 screws marked **(D)** .

#### [For C-20210]

SPEAKER ( × 1 )

#### [For AV-20220/AV-20221]

SPEAKER ( × 2 )

### CHECKING THE MAIN PW BOARD

1. To check the back side of the MAIN PW Board.
  - 1) Pull out the MAIN PWB. (Refer to REMOVING THE MAIN PWB).
  - 2) Erect the chassis vertically so that you can easily check the back side of the MAIN PW Board.

#### [CAUTION]

- When erecting the MAIN PWB, be careful so that there will be no contacting with other PW Board.
- Before turning on power, make sure that the CRT earth wire and other connectors are properly connected.

### WIRE CLAMPING AND CABLE TYING

1. Be sure clamp the wire.
2. Never remove the cable tie used for tying the wires together.  
Should it be inadvertently removed, be sure to tie the wires with a new cable tie.

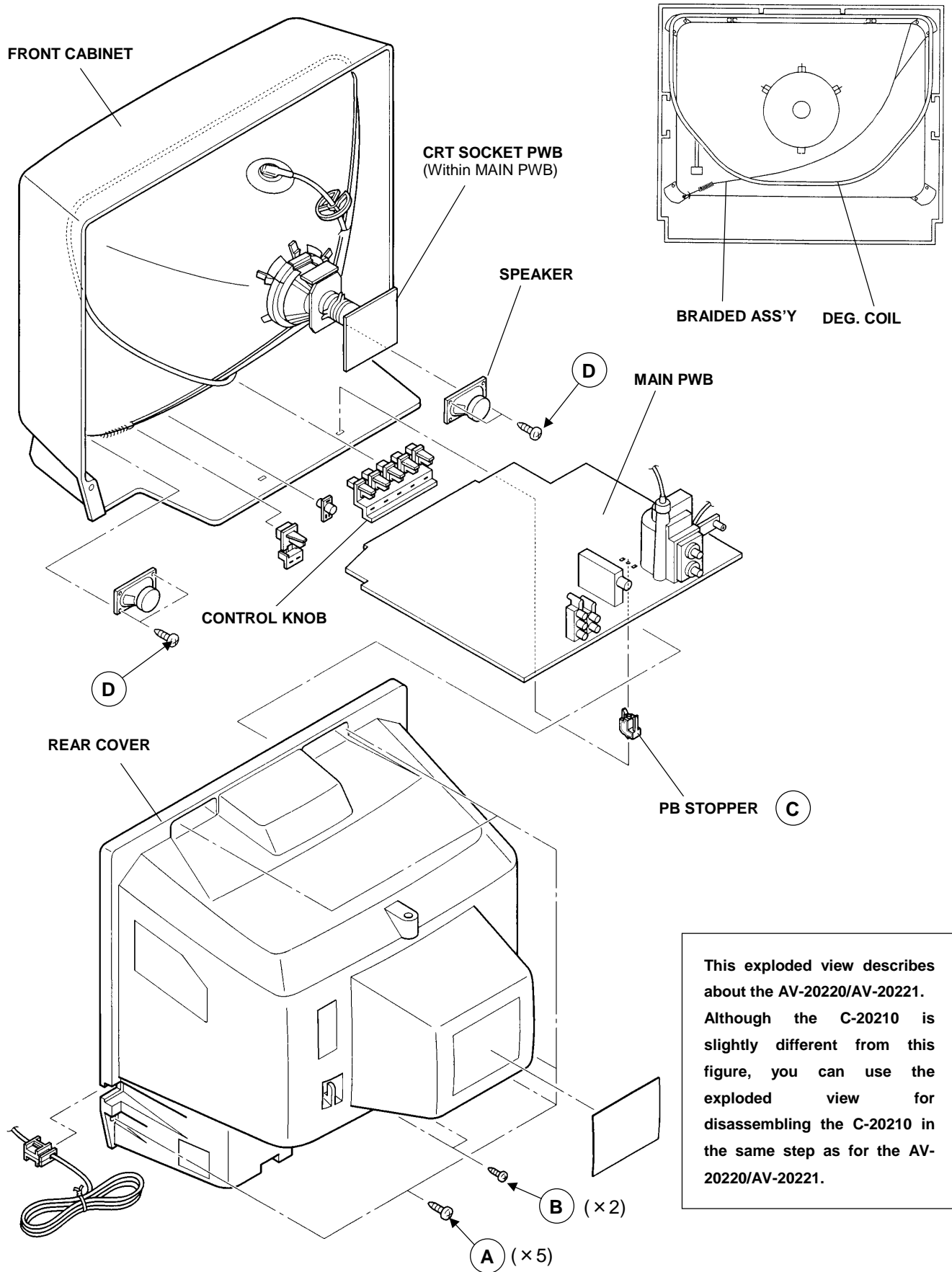

This exploded view describes about the AV-20220/AV-20221. Although the C-20210 is slightly different from this figure, you can use the exploded view for disassembling the C-20210 in the same step as for the AV-20220/AV-20221.

Fig.1

# MEMORY IC REPLACEMENT

## 1. Memory IC

This model use a memory IC.  
 This memory IC stores data for proper operation of the video and deflection circuits.  
 When replacing, be sure to use an IC containing this (initial value) data.

## 2. Memory IC replacement procedure

Procedure	Screen display										
<p><b>(1) Power off</b>            Switch off the power and disconnect the power cord from the outlet.</p>											
<p><b>(2) Replace the memory IC</b>            Initial value must be entered into the new IC.</p>											
<p><b>(3) Power on</b>            Connect the power cord to the outlet and switch on the power.</p>											
<p><b>(4) System constant check and setting</b></p> <ol style="list-style-type: none"> <li>1) Press <b>SLEEP TIMER</b> key and, while the indication of "<b>SLEEP TIMER 0 MIN.</b>" is being displayed, press <b>DISPLAY</b> key and <b>VIDEO STATUS</b> key on the remote control unit simultaneously.</li> <li>2) The SERVICE MENU screen of Fig.1 is displayed.</li> <li>3) While the SERVICE MENU is displayed, again simultaneously press the DISPLAY and VIDEO STATUS keys to display the Fig.2 SYSTEM CONSTANT screen.</li> <li>4) Refer to the SYSTEM CONSTANT table and check the setting items. Where these differ, select the setting item with the MENU UP/DOWN key and adjust the setting with the MENU LEFT/RIGHT keys. (The letters of the selected item are displayed in yellow.)</li> <li>5) After adjusting, release the MENU LEFT/RIGHT key to store the setting value.</li> <li>6) Press the EXIT key twice to return the normal screen.</li> </ol>	<div data-bbox="922 1010 1289 1279" style="border: 1px solid black; padding: 5px;"> <p style="text-align: center;">SERVICE MENU</p> <table style="width: 100%; border-collapse: collapse;"> <tr> <td style="width: 50%;">PICTURE</td> <td style="width: 50%;">SOUND ←</td> </tr> <tr> <td>GAME</td> <td>HIGH LIGHT</td> </tr> <tr> <td>LOW LIGHT</td> <td></td> </tr> <tr> <td>RF AFC CHK</td> <td></td> </tr> <tr> <td>VCO(CW)</td> <td></td> </tr> </table> <p style="font-size: small;">SELECT BY   ▲▼   EXIT BY            OPERATE BY   ◀▶   EXIT</p> </div> <p style="text-align: center;">Fig.1</p> <p style="text-align: right;">[AV-20220/21 Only]</p>	PICTURE	SOUND ←	GAME	HIGH LIGHT	LOW LIGHT		RF AFC CHK		VCO(CW)	
PICTURE	SOUND ←										
GAME	HIGH LIGHT										
LOW LIGHT											
RF AFC CHK											
VCO(CW)											
<p><b>(5) Receive channel setting</b>            Refer to the OPERATING INSTRUCTIONS(USER'S GUIDE) and set the receive channels (Channels Preset) as described.</p>	<div data-bbox="922 1487 1289 1756" style="border: 1px solid black; padding: 5px;"> <p style="text-align: center;">SYSTEM CONSTANT</p> <table style="width: 100%; border-collapse: collapse;"> <tr> <td style="width: 60%;">MODEL</td> <td style="width: 40%;">: ***** ←</td> </tr> <tr> <td>V-CHIP</td> <td>: YES</td> </tr> <tr> <td>CAN V-CHIP</td> <td>: YES</td> </tr> <tr> <td colspan="2" style="padding-top: 5px;">*****.*****</td> </tr> </table> <p style="font-size: small;">SELECT BY   ▲▼   EXIT BY            OPERATE BY   ◀▶   EXIT</p> </div> <p style="text-align: center;">Fig.2</p> <p style="text-align: right;">Indicated Model No.</p>	MODEL	: ***** ←	V-CHIP	: YES	CAN V-CHIP	: YES	*****.*****			
MODEL	: ***** ←										
V-CHIP	: YES										
CAN V-CHIP	: YES										
*****.*****											
<p><b>(6) User settings</b>            Check the user setting items according to Table 2.            Where these do not agree, refer to the OPERATING INSTRUCTIONS (USER'S GUIDE) and set the items as described.</p>											
<p><b>(7) SERVICE MENU setting</b>            Verify what to set in the SERVICE MENU, and set whatever is necessary.(Fig.1) Refer to the SERVICE ADJUSTMENT for setting.</p>											



TABLE 1 (System Constant setting)

Setting item	Setting content	Setting value	
		C-20210	AV-20220/21
MODEL	Display the each application model	Comformable model name	
V-CHIP	<input type="checkbox"/> YES <input type="checkbox"/> NO	YES	YES
CAN V-CHIP	<input type="checkbox"/> YES <input type="checkbox"/> NO	YES	YES

TABLE 2 (User setting value)

Setting item	Setting value
1. Use remote controller keys	
POWER	OFF
CHANNEL	CH 02
CHANNEL PRESET	See OPERATING INSTRUCTIONS.
VOLUME	10
INPUT (TV/VIDEO)	TV
DISPLAY	OFF
SLEEP TIMER	0
VIDEO STATUS	STANDARD
2. Setting of MENU	
TINT	CENTER
COLOR	CENTER
PICTURE	CENTER
BRIGHT	CENTER
DETAIL	CENTER
BASS	CENTER
TREBLE	CENTER
BALANCE	CENTER
MTS	STEREO
TV SPEAKER	ON
NOISE MUTING	ON
SET VIDEO STATUS	ALL CENTER
SET CLOCK	Unnecessary to set
ON/OFF TIMER	NO
LANGUAGE	ENG
CLOSED CAPTION	OFF
BACKGROUND	BLACK
AUTO TUNER SETUP	TUNER MODE : AIR
CHANNEL SUMMARY	Unnecessary to set
V-CHIP	OFF
SET LOCK CODE	Unnecessary to set

[AV-20220/21 Only]

# SERVICE ADJUSTMENTS

## ADJUSTMENT PREPARATION:

1. You can make the necessary adjustments for this unit with either the Remote Control Unit or With the adjustment tools and parts as given below.
2. Adjustment with the Remote Control Unit is made on the basis of the initial setting values, however, the new setting values which set the screen to its optimum condition may differ from the initial settings.
3. Make sure that AC power is turned on correctly.
4. Turn on the power for set and test equipment before use, and start the adjustment procedures after waiting at least 30 minutes.
5. Unless otherwise specified, prepare the most suitable reception or input signal for adjustment.

6. Never touch any adjustment parts which are not specified in the list for this adjustment - variable resistors, transformers, condensers, etc.
7. Presetting before adjustment.  
 Unless otherwise specified in the adjustment instructions, preset the following functions with the remote control unit:

VIDEO STATUS	STANDARD
BASS, TREBLE, BALANCE	CENTER (AV-20220/AV-20221)
TINT/COLOR PICTURE/BRIGHT DETAIL	CENTER

## ADJUSTMENT EQUIPMENT

1. DC voltmeter (or digital voltmeter)
2. Oscilloscope
3. Signal generator (Pattern generator) [NTSC]
4. Remote control unit
5. TV audio multiplex signal generator.
6. Frequency counter

## ADJUSTMENT ITEMS

Adjustment items	Adjustment items	Adjustment items (AV-20220/21)
B1 POWER SUPPLY	WHITE BALANCE (Low Light)	MTS INPUT LEVEL check
IF VCO	WHITE BALANCE (High Light)	MTS STEREO VCO
RF. AGC	SUB BRIGHT	MTS SAP VCO
FOCUS	SUB CONTRAST	MTS FILTER check
V. SIZE	SUB COLOR	MTS SEPARATION
H. POSITION	SUB TINT	

## ADJUSTMENT LOCATIONS

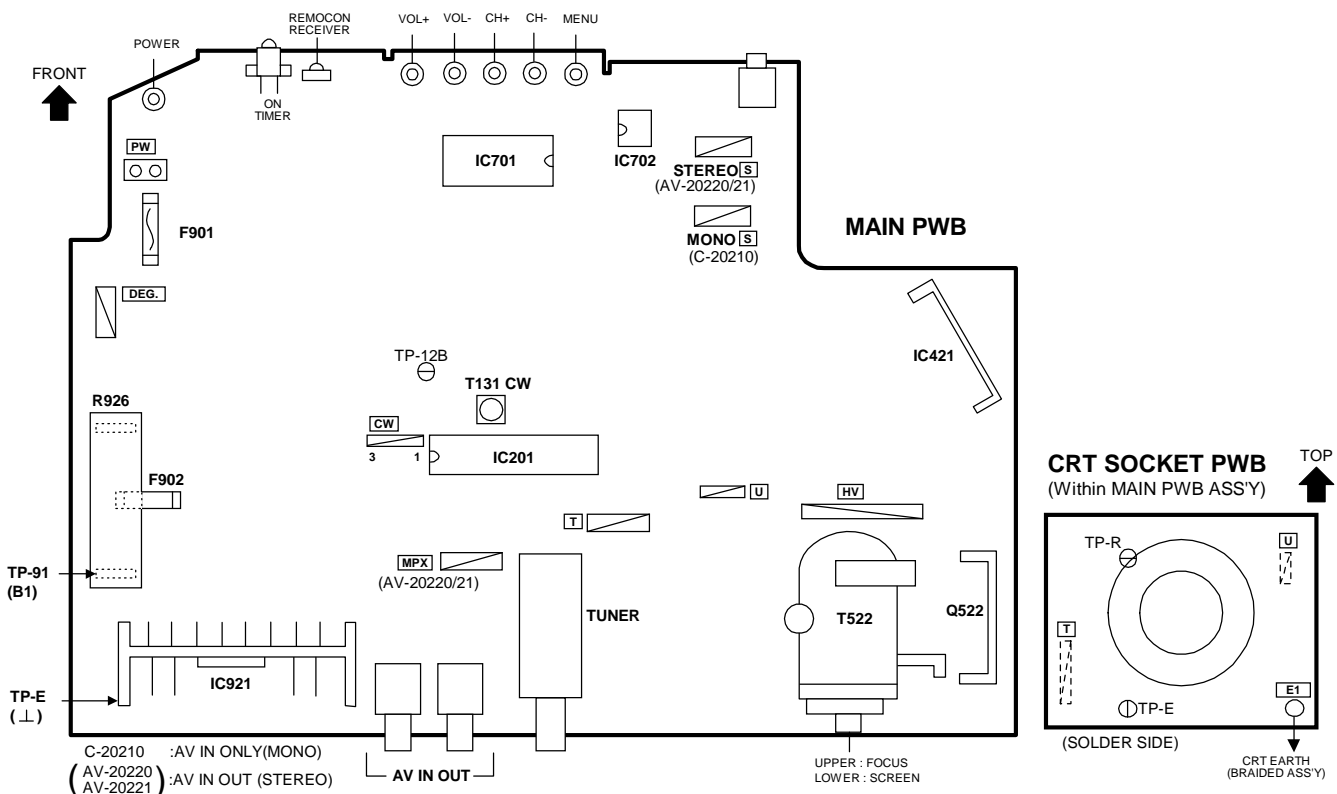

## BASIC OPERATION SERVICE MENU

### 1. TOOL OF SERVICE MENU OPERATION

Operate the SERVICE MENU with the REMOTE CONTROL UNIT.

### 2. SERVICE MENU ITEMS

In general, basic setting(adjustments) items or verifications are performed in the SERVICE MENU.

- PICTURE ..... This sets the setting values (adjustment values) of the VIDEO/CHROMA and DEFLECTION circuits.
- SOUND ..... This sets the setting values (adjustment values) of the AUDIO circuit. **[AV-20220/21 Only]**
- GAME ..... This is used when the GAME MODE is adjusted.
- LOW LIGHT ..... This sets the setting values (adjustment values) of the WHITE BALANCE circuit.
- HIGH LIGHT ..... This sets the setting values (adjustment values) of the WHITE BALANCE circuit.
- RF AFC CHK ..... This is used when the IF VCO is adjusted. **[Do not adjust]**
- VCO (CW) ..... This is used when the IF VCO is adjusted.

### 3. Basic Operations of the SERVICE MENU

#### (1) How to enter the SERVICE MENU.

Press **SLEEP TIMER** key and, while the indication of "SLEEP TIMER 0 MIN." is being displayed, press **DISPLAY** key and **VIDEO STATUS** key on the remote control unit simultaneously to enter the **SERVICE MENU** screen ① shown in the next figure page.

#### (2) SERVICE MENU screen selection

Press the UP / DOWN key of the MENU to select any of the following items.

(The letters of the selected items are displayed in yellow.)

- PICTURE
- SOUND **[AV-20220/21 Only]**
- GAME
- LOW LIGHT
- HIGH LIGHT
- RF AFC CHK
- VCO(CW)

#### (3) Enter the any setting ( adjustment ) mode

##### ● PICTURE and SOUND mode

- 1) If select any of PICTURE or SOUND items, and the LEFT / RIGHT key is pressed from SERVICE MENU ( MAIN MENU ), the screen ② will be displayed as shown in figure page later.
- 2) Then the UP / DOWN key is pressed, the PICTURE mode screen ③ or the SOUND mode screen ④ is displayed, and the PICTURE or SOUND setting can be performed.

##### ● GAME, LOW LIGHT, HIGH LIGHT, RF AFC CHK and VCO (CW) mode

- 1) If select any of GAME / LOW LIGHT / HIGH LIGHT / RF AFC CHK / VCO (CW) items, and the LEFT / RIGHT key is pressed from SERVICE MENU ( MAIN MENU ), the screens ⑤ ⑥ ⑦ ⑧ ⑨ will be displayed as shown in figure page later.
- 2) Then the settings or verifications can be performed.



**(4) Setting method**

- 1) UP / DOWN key of the MENU  
Select the SETTING ITEM.
- 2) LEFT / RIGHT key of the MENU  
Setting(adjust) the SETTING VALUE of the SETTING ITEM.  
When the key is released the SETTING VALUE will be stored (memorized).
- 3) EXIT key  
Returns to the previous screen.

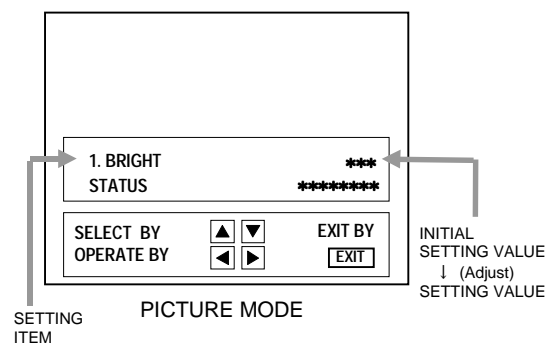

**(5) Releasing SERVICE MENU**

- 1) After returning to the SERVICE MENU upon completion of the setting (adjustment) work, press the EXIT key again.

★ The settings for LOW LIGHT and HIGH LIGHT are described in the WHITE BALANCE page of ADJUSTMENT.

★ The setting for VCO(CW) are described in the IF VCO page of ADJUSTMENT.

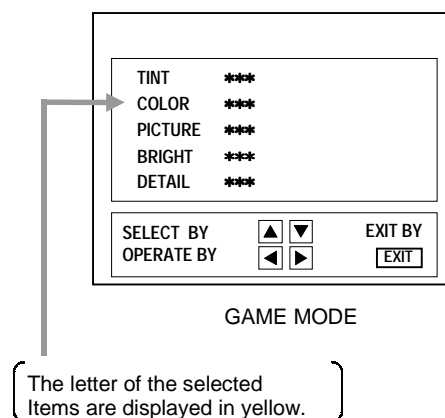
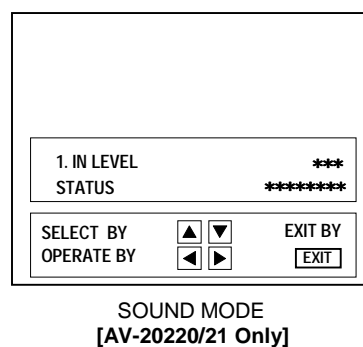

## INITIAL SETTING VALUE OF SERVICE MENU

- Adjustment of the SERVICE MENU is made on the basis of the initial setting values; however, the new setting values which set the screen in its optimum condition may differ from the initial setting.
- Do not change the initial setting values of the setting (Adjustment) items not listed in "ADJUSTMENT" .

### ● PICTURE MODE

- ◇ The four setting items in the video mode No.7 EXT BRI., No.8 EXT PIC., No.11 EXT TINT and No.12 EXT COL. are linked to the items in the TV MODE No.1 BRIGHT, No.2 PICTURE, No.5 TINT and No.6 COLOR, respectively. When the setting items in the TV mode are adjusted, the values in the setting items in the video mode are revised automatically to the same values in the TV mode.(The initial setting values given in ( ) are off-set values.)
- ◇ When the four items (No.7, 8, 11 and 12) are adjusted in the video mode, the setting values in each item are revised independently.

No.	Setting (Adjustment) items	Variable range	initial setting value	
			C-20210	AV-20220 AV-20221
1.	BRIGHT	0 ~ 127	64	64
2.	PICTURE	0 ~ 127	95	95
3.	TV DTL(TV DETAIL)	0 ~ 63	26	26
4.	TV BPF(TV B.P.FILTER)	0 / 1	0	0
5.	TINT	0 ~ 127	70	70
6.	COLOR	0 ~ 127	48	48
7.	EXT BRI.(EXT.BRIGHT)	±25	(-1)	(±0)
8.	EXT PIC.(EXT.PICTURE)	±25	(±0)	(±0)
9.	EXT DTL(EXT.DETAIL)	0 ~ 63	26	26
10.	EXT BPF(EXT.B.P.FILTER)	0 / 1	0	0
11.	EXT TINT	±25	(±0)	(+1)
12.	EXT COL.(EXT.COLOR)	±25	(±0)	(+3)
13.	V SIZE	0 ~ 63	38	38
14.	V CENT.(V.CENTER)	0 ~ 7	0	0
15.	H POS.(H.POSITION)	0 ~ 31	20	20
16.	OSD HP (OSD H POSITION)	0 ~ 31	26	26
17.	OSD VP (OSD V POSITION)	0 ~ 15	14	14
18.	H. AFC	0 / 1	0	0
19.	RF AGC	0 ~ 63	40	40

### ● SOUND MODE [AV-20220/AV-20221 Only]

No.	Setting (Adjustment) item	Variable range	Initial setting value
1.	IN LEVEL (INPUT LEVEL)	0~63	29
2.	FH MON. (FM MONITOR)	0 / 1	0
3.	ST VCO (STEREO VCO)	0~63	20
4.	PILOT (PILOT CANCELER)	0 / 1	0
5.	FILTER	0~63	25
6.	LOW SEP. (LOW SEPARATION)	0~63	32
7.	HI SEP. (HI SEPARATION)	0~63	16
8.	5FH MON. (5FH MONITOR)	0 / 1	0
9.	SAP VCO	0~63	14
10.	FIL. OFF.	±10	0

● GAME MODE

Setting (Adjustment) item	Variable range	Initial setting value
TINT	±20	±0
COLOR	±20	±0
PICTURE	±20	-10
BRIGHT	±20	-5
DETAIL	±15	+5

● LOW LIGHT MODE

Setting (Adjustment) item	Variable range	initial setting value
R CUTOFF	0 ~ 255	20
G CUTOFF	0 ~ 255	20
B CUTOFF	0 ~ 255	20

● HIGH LIGHT MODE

Setting (Adjustment) item	Variable range	initial setting value
G DRIVE	0 ~ 255	128
B DRIVE	0 ~ 255	128

● RF AFC CHK MODE

Setting (Adjustment) item	Variable range	initial setting value
RF AFC	ON / OFF	ON
FINE	-77 ~ +77	± × × <b>( DO NOT ADJUST )</b>

## ■ ADJUSTMENTS

### B1 POWER SUPPLY

Item	Measuring instrument	Test point	Adjustment part	Description
Check of B1 POWER SUPPLY	DC Voltmeter	TP-91 (B1) TP-E(L)		<ol style="list-style-type: none"> <li>1. Receive a black-and-white signal.</li> <li>2. Connect the DC Voltmeter to TP-91 (B1) and TP-E(L).</li> <li>3. Confirm that the voltage is DC134V +2V -2.5V.</li> </ol>

### ADJUSTMENT OF VIDEO / DEF. CIRCUIT

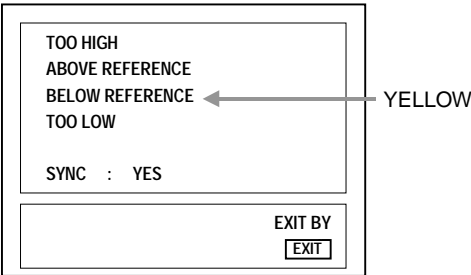
Item	Measuring instrument	Test point	Adjustment part	Description
IF VCO adjustment	Signal generator		CW TRANSF. (T131) [VCO(CW)] MODE	<ul style="list-style-type: none"> <li>● Under normal conditions, no adjustment is required.</li> </ul> <ol style="list-style-type: none"> <li>1. Receive a NTSC broadcast. (use channels without offset frequency).</li> <li>2. Select the VCO(CW) mode from the SERVICE MENU.</li> <li>3. Confirm the color change (yellow) from "TOO HIGH" to "TOO LOW" by CW TRANSF. and "SYNC : YES" being shown on the screen. Then, adjust CW TRANSF. until "BELOW REFERENCE" mark turns yellow and confirm again " SYNC : YES" being shown on the screen.</li> </ol>
				
RF. AGC adjustment			No.19 RF AGC	<ol style="list-style-type: none"> <li>1. Receive a broadcast.</li> <li>2. Select "No.19 RF AGC" of the PICTURE MODE.</li> <li>3. Press the MUTE key and turn off color.</li> <li>4. With the MENU LEFT key, get noise in the screen picture. (0 side of setting value)</li> <li>5. Press the MENU RIGHT key and stop when noise disappears from the screen.</li> <li>6. Change to other channels and make sure that there is no irregularity.</li> <li>7. Press the MUTE key and get color out.</li> </ol>
FOCUS adjustment	Signal generator		FOCUS VR [In HVT]	<ol style="list-style-type: none"> <li>1. Receive a crosshatch signal.</li> <li>2. While looking at the screen, adjust FOCUS VR so that the vertical and horizontal lines will be clear and in fine detail.</li> <li>3. Make sure that the picture is in focus even when the screen gets darkened.</li> </ol>

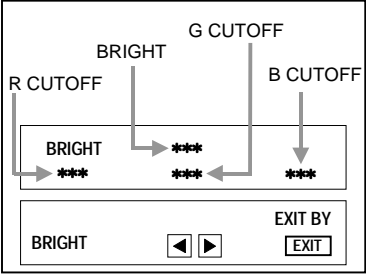
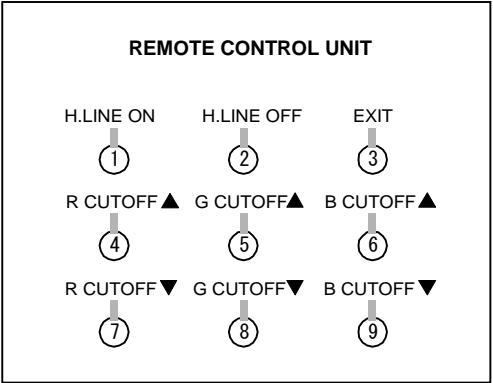
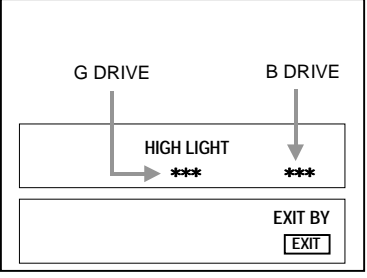

Item	Measuring instruments	Test point	Adjustment part	Description
<b>V.SIZE Adjustment</b>	<b>Signal generator</b>		<b>No.13 V.SIZE</b>	<ol style="list-style-type: none"> <li>1. Receive a crosshatch signal.</li> <li>2. Select No.13 V SIZE in the PICTURE MODE.</li> <li>3. Set the initial setting value of No.13 V SIZE with the LEFT / RIGHT key of the MENU.</li> <li>4. Adjust No.13 V SIZE until the vertical screen size is 92%.</li> </ol>
				<ol style="list-style-type: none"> <li>1. Receive a crosshatch signal.</li> <li>2. Select the No.15 H POS. of the PICTURE MODE.</li> <li>3. Set the initial setting value of the No.15 H POS. with the LEFT / RIGHT key of the MENU.</li> <li>4. Adjust the No.15 H POS. until the screen will be horizontally centered.</li> </ol>
<b>H.POSITION Adjustment</b>	<b>Signal generator</b>		<b>No.15 H POS.</b>	<ol style="list-style-type: none"> <li>1. Receive a crosshatch signal.</li> <li>2. Select the No.15 H POS. of the PICTURE MODE.</li> <li>3. Set the initial setting value of the No.15 H POS. with the LEFT / RIGHT key of the MENU.</li> <li>4. Adjust the No.15 H POS. until the screen will be horizontally centered.</li> </ol>

Item	Measuring instruments	Test point	Adjustment part	Description
<b>WHITE BALANCE (Low Light) Adjustment</b>	Signal generator		<b>BRIGHT</b>  <b>R. CUTOFF</b> <b>G. CUTOFF</b> <b>B. CUTOFF</b>  <b>SCREEN VR [In HVT]</b>	<ol style="list-style-type: none"> <li>1. Receive a black-and-white signal.(Color off)</li> <li>2. Select the <b>[LOW LIGHT] MODE</b> from the SERVICE MENU.</li> <li>3. Set the initial setting value of BRIGHT with the LEFT / RIGHT key of the remote control unit.</li> <li>4. Set the initial setting value of R CUTOFF, G CUTOFF and B CUTOFF with the ④ to ⑨ key of the remote control unit.</li> <li>5. Display a single horizontal line by pressing the ①key of the remote control unit.</li> <li>6. Turn the screen VR all the way to the left.</li> <li>7. Turn the screen VR gradually to the right from the left until either one of the red, blue or green colors appears faintly.</li> <li>8. Adjust the two colors which did not appear until the single horizontal line that is displayed becomes white using the ④ to ⑨ keys of the remote control unit.</li> <li>9. Turn the screen VR to where the single horizontal line glows faintly.</li> <li>10. Press the ② key to return to the regular screen.</li> </ol> <p>* The ③ EXIT key is the cancel key for the WHITE BALANCE.</p>
<div style="text-align: center;"> <p><b>[LOW LIGHT] MODE</b></p>  </div> <div style="text-align: center;"> <p><b>REMOTE CONTROL UNIT</b></p>  </div>				
<b>WHITE BALANCE (High Light) Adjustment</b>	Signal generator		<b>G. DRIVE</b> <b>B. DRIVE</b>	<ol style="list-style-type: none"> <li>1. Receive a black-and-white signal. (Color off)</li> <li>2. Select the <b>[HIGH LIGHT] MODE</b> in the SERVICE MENU.</li> <li>3. Set the initial setting value of G DRIVE and B DRIVE with the ⑤, ⑥, ⑧ and ⑨ keys of the remote control unit.</li> <li>4. Adjust the screen until it becomes white using the ⑤, ⑥, ⑧ and ⑨ keys of the remote control unit.</li> </ol> <p>* The ③ (EXIT) key is the cancel key for the WHITE BALANCE.</p>
<div style="text-align: center;"> <p><b>[HIGH LIGHT] MODE</b></p>  </div> <div style="border: 1px solid black; padding: 5px; width: fit-content; margin-left: auto; margin-right: auto;"> <p><b>Remote Control Unit</b></p> <p>① key : H.LINE ON</p> <p>② key : H.LINE OFF</p> <p>③ key : EXIT</p> <p>⑤ key : G DRIVE ▲</p> <p>⑥ key : B DRIVE ▲</p> <p>⑧ key : G DRIVE ▼</p> <p>⑨ key : B DRIVE ▼</p> </div>				

Item	Measuring instruments	Test point	Adjustment part	Description
<b>SUB BRIGHT Adjustment</b>			<b>No.1 BRIGHT</b>	<ol style="list-style-type: none"> <li>1. Receive a broadcast.</li> <li>2. Select No.1 BRIGHT of the PICTURE MODE.</li> <li>3. Set the initial setting value of the No.1 BRIGHT with the LEFT / RIGHT key of the MENU.</li> <li>4. If the brightness is not best with the initial setting value, make fine adjustment of the No.1 BRIGHT until you get the optimum brightness.</li> </ol>
<b>SUB CONTRAST Adjustment</b>			<b>No.2 PICTURE</b>	<ol style="list-style-type: none"> <li>1. Receive a broadcast.</li> <li>2. Select No.2 PICTURE of the PICTURE MODE.</li> <li>3. Set the initial setting value of the No.2 PICTURE with the LEFT / RIGHT key of the MENU.</li> <li>4. If the contrast is not best with the initial setting value, make fine adjustment of the No.2 PICTURE until you get the optimum contrast.</li> </ol>
<b>SUB COLOR Adjustment</b>			<b>No.6 COLOR</b>	<ol style="list-style-type: none"> <li>1. Receive a broadcast.</li> <li>2. Select No.6 COLOR of the PICTURE MODE.</li> <li>3. Set the initial setting value of the No.6 COLOR with the LEFT / RIGHT key of the MENU.</li> <li>4. If the color is not best with the initial setting value, make fine adjustment of the No.6 COLOR until you get the optimum color.</li> </ol>
<b>SUB TINT Adjustment</b>			<b>No.5 TINT</b>	<ol style="list-style-type: none"> <li>1. Receive a broadcast.</li> <li>2. Select No.5 TINT of the PICTURE MODE.</li> <li>3. Set the initial setting value of the No.5 TINT with the LEFT / RIGHT key of the MENU.</li> <li>4. If the tint is not best with the initial setting value, make fine adjustment of the No.5 TINT until you get the optimum tint.</li> </ol>

#### ADJUSTMENT OF MTS CIRCUIT [AV-20220 / AV-20221 Only]

Item	Measuring instrument	Test point	Adjustment part	Description
<b>MTS INPUT LEVEL check</b>			<b>No.1 IN LEVEL</b>	<ol style="list-style-type: none"> <li>1. Select the "No.1 IN LEVEL" of the SOUND MODE.</li> <li>2. Verify that the "No.1 IN LEVEL" is set at its initial setting value.</li> </ol>
<b>MTS STEREO VCO adjustment</b>	Signal generator Frequency counter	R OUT [AUDIO OUT]	<b>No.2 FH MON.</b> <b>No.3 ST VCO</b>	<ol style="list-style-type: none"> <li>1. Receive a RF signal (nonmodulated sound signal) from the antenna terminal.</li> <li>2. Select the "No.2 FH MON." of SOUND MODE, and change the setting value from 0 to 1.</li> <li>3. Connect the Frequency Counter to R OUT RCA pin of the AUDIO OUT.</li> <li>4. Select the "No.3 ST VCO".</li> <li>5. Set the initial setting value of the "No.3 ST VCO" with the LEFT/RIGHT key of the menu.</li> <li>6. Adjust the "No.3 ST VCO" so that the Frequency Counter will display 15.73kHz±0.1kHz.</li> <li>7. Select the "No.2 FH MON." of the SOUND MODE, and reset the setting value from 1 to 0.</li> </ol>

Item	Measuring instrument	Test point	Adjustment part	Description
MTS SAP VCO adjustment	Signal generator  Frequency counter	<b>【MPX】 Connector</b> <b>【4】 pin SDA</b> <b>【3】 pin GND</b>  R OUT <b>[AUDIO OUT]</b>	<b>No.8 5FH MON.</b>  <b>No.9 SAP VCO</b>	<ol style="list-style-type: none"> <li>1. Receive a RF signal (non modulated sound signal) from the antenna terminal.</li> <li>2. Connect between pin <b>【4】</b> of <b>【MPX】</b> connector and GND (Pin <b>【3】</b> of <b>【MPX】</b> connector) through 1MΩ Resistor.</li> <li>3. Select the "No.8 5FH MON." of the SOUND MODE, and reset the setting value from 0 to 1.</li> <li>4. Connect the Frequency Counter to R OUT RCA pin of the AUDIO OUT.</li> <li>5. Select the "No.9 SAP VCO".</li> <li>6. Set the initial setting value of "No.9 SAP VCO" with the LEFT/RIGHT key of the menu.</li> <li>7. Adjust the "No.9 SAP VCO" so that the Frequency Counter will display 78.67kHz±0.5kHz.</li> <li>8. Select the "No.8 5FH MON." of the SOUND MODE, and reset the setting value from 1 to 0.</li> </ol>
MTS FILTER check			<b>No.5 FILTER</b>	<ol style="list-style-type: none"> <li>1. Select the "No.5 FILTER" of the SOUND MODE.</li> <li>2. Verify that the "No.5 FILTER" is set at its initial setting value.</li> </ol>
MTS SEPARATION adjustment	TV audio multiplex signal generator  Oscilloscope	L OUT R OUT <b>[AUDIO OUT]</b>	<b>No.6 LOW SEP.</b>  <b>No.7 HI SEP.</b>	<ol style="list-style-type: none"> <li>1. Input a stereo L signal (300Hz) from the TV audio multiplex signal generator to the antenna terminal.</li> <li>2. Connect an oscilloscope to L OUT RCA pin of the AUDIO OUT, and display one cycle portion of the 300Hz signal.</li> <li>3. Change the connection of the oscilloscope to R OUT RCA pin of the AUDIO OUT, and enlarge the voltage axis.</li> <li>4. Select the "No.6 LOW SEP." of the SOUND MODE.</li> <li>5. Set the initial setting value of the "No.6 LOW SEP." with the LEFT/RIGHT key of the menu.</li> <li>6. Adjust the "No.6 LOW SEP." so that the stroke element of the 300Hz signal will become minimum.</li> <li>7. Change the signal to 3kHz, and similarly adjust the "No.7 HI SEP."</li> </ol>

L-Channel signal waveform                      R-Channel crosstalk portion

↓ Minimum

↑

1 cycle

## PURITY, CONVERGENCE

### PURITY ADJUSTMENT

1. Demagnetize CRT with the demagnetizer.
2. Loosen the retainer screw of the deflection yoke.
3. Remove the wedges.
4. Input a green raster signal from the signal generator, and turn the screen to green raster.
5. Move the deflection yoke backward.
6. Bring the long lug of the purity magnets on the short lug and position them horizontally. (Fig.2)
7. Adjust the gap between two lugs so that the GREEN RASTER will come into the center of the screen. (Fig.3)
8. Move the deflection yoke forward, and fix the position of the deflection yoke so that the whole screen will become green.
9. Insert the wedge to the top side of the deflection yoke so that it will not move.
10. Input a crosshatch signal.
11. Verify that the screen is horizontal.
12. Input red and blue raster signals, and make sure that purity is properly adjusted.

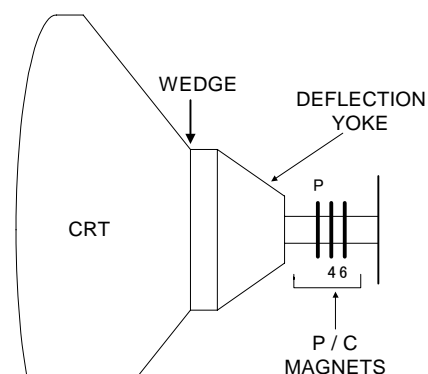

#### • P/C MAGNETS

P : PURITY MAGNET  
 4 : 4 POLES (convergence magnets)  
 6 : 6 POLES (convergence magnets)

Fig.1

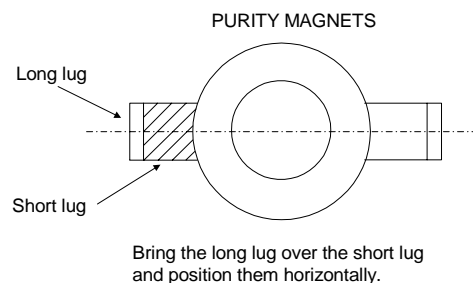

Fig.2

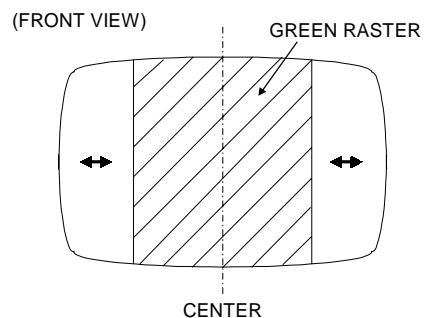
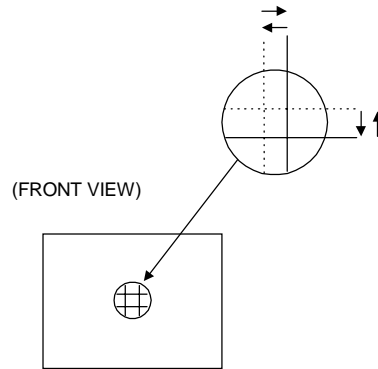

Fig.3

**STATIC CONVERGENCE ADJUSTMENT**

1. Input a crosshatch signal.
2. Using 4-pole convergence magnets, overlap the red and blue lines in the center of the screen (Fig.1) and turn them to magenta (red/blue).
3. Using 6-pole convergence magnets, overlap the magenta(red/blue) and green lines in the center of the screen and turn them to white.
4. Repeat 2 and 3 above, and make best convergence.



**Fig.1**

**DYNAMIC CONVERGENCE ADJUSTMENT**

1. Move the deflection yoke up and down and overlap the lines in the periphery. (Fig. 2)
2. Move the deflection yoke left to right and overlap the lines in the periphery. (Fig. 3)
3. Repeat 1 and 2 above, and make best convergence.

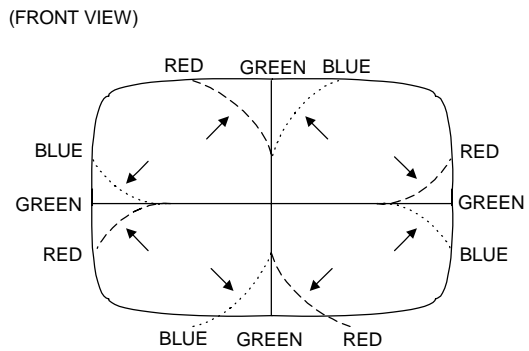

**Fig.2**

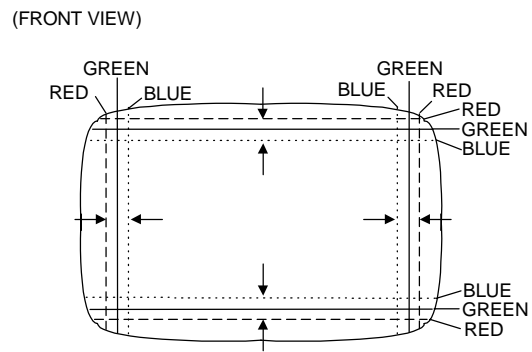

**Fig.3**

- After adjustment, fix the wedge at the original position.  
 Fasten the retainer screw of the deflection yoke.  
 Fix the 6 magnets with glue.

## HOW TO CHECK THE HIGH VOLTAGE HOLD DOWN CIRCUIT

### 1. HIGH VOLTAGE HOLD DOWN CIRCUIT

After repairing the high voltage hold down circuit shown in Fig. 1.  
 This circuit shall be checked to operate correctly.

### 2. CHECKING OF THE HIGH VOLTAGE HOLD DOWN CIRCUIT

- (1) Turn the POWER SW ON.
- (2) As shown in Fig. 1, set the resistor (between  connector  1 &  3 ).
- (3) Make sure that the screen picture disappears.
- (4) Temporarily unplug the power cord.
- (5) Remove the resistor (between  connector  1 &  3 ).
- (6) Again plug the power cord, make sure that the normal picture is displayed on the screen.

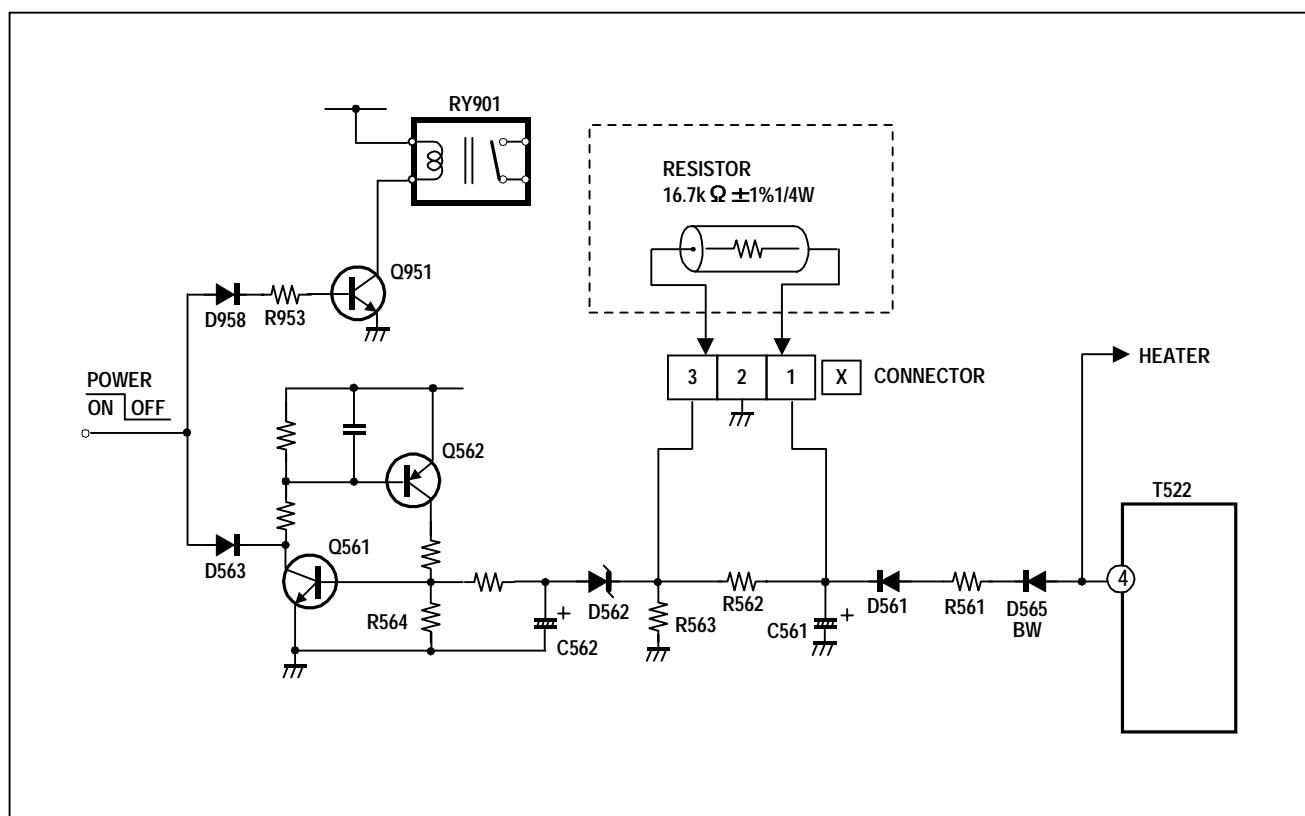

Fig. 1

## SELF CHECK FUNCTIONS

### 1. Outline

This model has self check functions given below. When a malfunction has been detected, the POWER is turned off and the LED flashes to inform of the failure . The malfunction is detected by the signal input state of the control line connected to the microcomputer.

### 2. Self check items

Check item	Details of detection	Method of detection	State of malfunction
CRT NECK protector ( Also detected if the power supply line output from the HVT (High voltage Transformer) has shorted with the ground. )	When the vertical circuit S-correction capacitor C427 is shorted, detect the potential drop of the C427, and prevent the burn damage to the CRT NECK. (Grounding of shorting of the power supply output from the HVT to the vertical circuit, and the small signal power supply is also detected.)	The microcomputer detects at 1 second intervals. If NG is detected for more than 1 ms, a malfunction is interpreted.	When a malfunction has been detected, the POWER is turned off. While the POWER is being turned off , the power key of the remote controller is not operational until the power code is taken out and put in again.

### 3. Self check indicating function

The self-check function begins detection about 5 seconds after power is supplied.

In the event a malfunction is detected, the power is cut off immediately.

At this time, the ON-TIMER LED flashes to inform of the malfunction.

#### [ON-TIMER LED indication]

The ON-TIMER LED flashes at 0.5 seconds intervals.

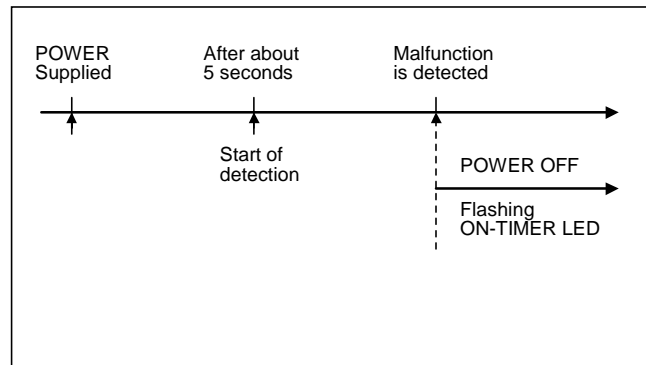



## JVC SERVICE & ENGINEERING COMPANY OF AMERICA DIVISION OF JVC AMERICAS CORP.

<b>Head office :</b>	1700 Valley Road, Wayne, New Jersey 07470	(973)315-5000
<b>East Coast :</b>	10 New Maple Avenue, Pine Brook, New Jersey 07058	(973)396-1000
<b>Midwest :</b>	705 Enterprise St. Aurora, Illinois 60504	(630)851-7855
<b>West Coast :</b>	5665 Corporate Avenue, Cypress, California 90630	(714)229-8011
<b>Southwest :</b>	10700 Hammerly, Suite 105, Houston, Texas 77043	(713)935-9331
<b>Hawaii :</b>	2969 Mapunapuna Place, Honolulu, Hawaii 96819	(808)833-5828
<b>Southeast :</b>	1500 Lakes Parkway, Lawrenceville, Georgia 30243	(770)339-2582

## JVC CANADA INC.

<b>Head office :</b>	21 Finchdene Square Scarborough, Ontario M1X 1A7	(416)293-1311
<b>Vancouver :</b>	13040 Worster Court Richmond B.C. V6V 2B3	(604)270-1311

# JVC®



# JVC

# SCHEMATIC DIAGRAMS

## COLOR TELEVISION

BASIC CHASSIS

FV4

# C-20210<sub>/s</sub> AV-20220<sub>/s</sub> AV-20221<sub>/s</sub>

CD-ROM No.SML200102

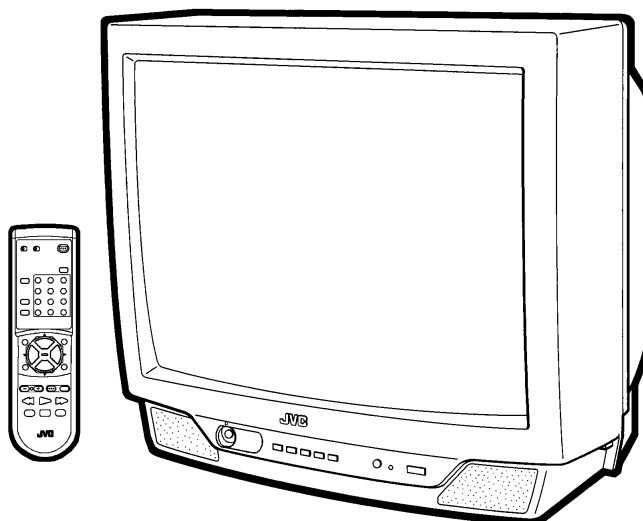

## CONTENTS

■ NOTE ON USING CIRCUIT DIAGRAMS .....	2-1
■ SEMICONDUCTOR SHAPES .....	2-2
■ BLOCK DIAGRAMS .....	2-3
■ CIRCUIT DIAGRAMS .....	2-7
■ PATTERN DIAGRAMS .....	2-13
■ CHANNEL CHART .....	2-15

### CHANNEL CHART [CA]

MODE		BAND	CHANNEL		TUNER BAND	
TV	CATV		REAL	DISP.		
○	○	VL	02	I		
			03			
			04			
		05				
		06				
		07				
	VH	08				
		09				
		10				
		11				
		12				
		13				
		x	○	MID	A	14
B	15					
C	16					
D	17					
E	18					
F	19					
G	20					
H	21					
I	22					
SUPER	J			23		
	K			24		
	L			25		
	M			26		
	N			27		
	O		28			
	P		29			
	Q		30			
	R		31			
S	32					
T	33					
U	34					
V	35					
W	36					
○	○		HYPER	W+1	37	III
				W+2	38	
				W+3	39	
				W+4	40	
				W+5	41	
		W+6		42		
		W+7		43		
		W+8		44		
		W+9		45		
		W+10		46		
		W+11		47		
		W+12		48		
		W+13		49		
		W+14		50		
W+15		51				
W+16		52				
W+17		53				
W+18		54				
W+19		55				
W+20		56				
W+21		57				
W+22		58				
W+23		59				
W+24		60				
W+25		61				
W+26		62				
W+27		63				
W+28		64				
ULTRA	W+29	65				
	W+30	66				
	W+31	67				
	W+32	68				
	W+33	69				
	W+34	70				

MODE		BAND	CHANNEL		TUNER BAND				
TV	CATV		REAL	DISP.					
x	○	ULTRA	W+35	71	IV				
			W+36	72					
			W+37	73					
			W+38	74					
			W+39	75					
			W+40	76					
			W+41	77					
			W+42	78					
			W+43	79					
			W+44	80					
			W+45	81					
			W+46	82					
			W+47	83					
			W+48	84					
			W+49	85					
			W+50	86					
			W+51	87					
			W+52	88					
			W+53	89					
			W+54	90					
			W+55	91					
			W+56	92					
			W+57	93					
			W+58	94					
			W+59	100					
			W+60	101					
			W+61	102					
			W+62	103					
			W+63	104					
			W+64	105					
			W+65	106					
			W+66	107					
			W+67	108					
			W+68	109					
			W+69	110					
			W+70	111					
			W+71	112					
			W+72	113					
			W+73	114					
			W+74	115					
			W+75	116					
			W+76	117					
			W+77	118					
			W+78	119					
			W+79	120					
			W+80	121					
			W+81	122					
			W+82	123					
			W+83	124					
			W+84	125					
			SUB MID	A-8		01	I		
				A-4		96			
				A-3		97			
				A-2		98			
				A-1		99			
			○	x		UHF	14 } 69	IV	
			TOTAL 180CH { VHF 124CH { UHF 56CH						
			NOTE: TO RECEIVE THE SUBSCRIPTION OR PREMIUM PROGRAMMING FROM CERTAIN CABLE COMPANIES. SPECIAL ADAPTERS MAY BE REQUIRED.						

# C-20210<sub>IS</sub> / AV-20220<sub>IS</sub> / AV-20221<sub>IS</sub> STANDARD CIRCUIT DIAGRAM

## NOTE ON USING CIRCUIT DIAGRAMS

### 1. SAFETY

The components identified by the  $\Delta$  symbol and shading are critical for safety. For continued safety replace safety critical components only with manufactures recommended parts.

### 2. SPECIFIED VOLTAGE AND WAVEFORM VALUES

The voltage and waveform values have been measured under the following conditions.

- (1) Input signal : Color bar signal
  - (2) Setting positions of each knob/button and variable resistor : Original setting position when shipped
  - (3) Internal resistance of tester : DC 20k  $\Omega$  / V
  - (4) Oscilloscope sweeping time : H  $\Rightarrow$  20 $\mu$ S/div  
: V  $\Rightarrow$  5mS/div  
: Others  $\Rightarrow$  Sweeping time is specified
  - (5) Voltage values : All DC voltage values
- \* Since the voltage values of signal circuit vary to some extent according to adjustments, use them as reference values.

### 3. INDICATION OF PARTS SYMBOL [EXAMPLE]

● In the PW board : R1209  $\rightarrow$  R209

### 4. INDICATIONS ON THE CIRCUIT DIAGRAM

#### (1) Resistors

- Resistance value  
No unit : [ $\Omega$ ]  
K : [K  $\Omega$ ]  
M : [M  $\Omega$ ]
- Rated allowable power  
No indication : 1/10[W]  
Others : As specified

#### ● Type

- No indication : Carbon resistor
- OMR : Oxide metal film resistor
- MFR : Metal film resistor
- MPR : Metal plate resistor
- UNFR : Uninflammable resistor
- FR : Fusible resistor

\* Composition resistor 1/2 [W] is specified as 1/2S or Comp.

#### (2) Capacitors

- Capacitance value  
1 or higher : [pF]  
less than 1 : [ $\mu$ F]
- Withstand voltage  
No indication : DC50[V]  
AC indication : AC withstand voltage [V]  
Others : DC withstand voltage [V]

\* Electrolytic Capacitors



47/50[Example]: Capacitance value [ $\mu$ F]/withstand voltage[V]

- Type  
No indication : Ceramic capacitor  
MY : Mylar capacitor  
MM : Metalized mylar capacitor  
PP : Polypropylene capacitor  
MPP : Metalized polypropylene capacitor  
MF : Metalized film capacitor  
TF : Thin film capacitor  
BP : Bipolar electrolytic capacitor  
TAN : Tantalum capacitor

#### (3) Coils

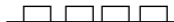

- No unit : [ $\mu$ H]
- Others : As specified

#### (4) Power Supply



-  : B1
-  : 12V
-  : 9V
-  : 5V

\* Respective voltage values are indicated



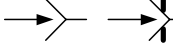

#### (5) Test point

-  : Test point
-  : Only test point display

#### (6) Connecting method

-  : Connector
-  : Wrapping or soldering
-  : Receptacle

#### (7) Ground symbol

-  : LIVE side ground
-  : ISOLATED(NEUTRAL) side ground
-  : EARTH ground
-  : DIGITAL ground

## 5. NOTE FOR REPAIRING SERVICE

This model's power circuit is partly different in the GND. The difference of the GND is shown by the LIVE : (  $\perp$  ) side GND and the ISOLATED(NEUTRAL) : (  $\neq$  ) side GND. Therefore, care must be taken for the following points.

- (1) Do not touch the LIVE side GND or the LIVE side GND and the ISOLATED(NEUTRAL) side GND simultaneously. If the above caution is not respected, an electric shock may be caused. Therefore, make sure that the power cord is surely removed from the receptacle when, for example, the chassis is pulled out.
- (2) Do not short between the LIVE side GND and ISOLATED(NEUTRAL) side GND or never measure with a measuring apparatus ( oscilloscope, etc.) the LIVE side GND and ISOLATED(NEUTRAL) side GND at the same time. If the above precaution is not respected , a fuse or any parts will be broken.

◇ Since the circuit diagram is a standard one, the circuit and circuit constants may be subject to change for improvement without any notice.

# CONTENTS

**SEMICONDUCTOR SHAPES** ..... 2-2

**BLOCK DIAGRAM**

    C-20210 ..... 2-3

    AV-20220/ AV-20221 ..... 2-5

**CIRCUIT DIAGRAMS**

    MAIN PWB CIRCUIT DIAGRAM [C-20210] ..... 2-7

    MAIN PWB CIRCUIT DIAGRAM [AV-20220/ AV-20221] ..... 2-9

    MAIN PWB, CRT SOCKET PWB CIRCUIT DIAGRAM ..... 2-11

**PATTERN DIAGRAMS**

    MAIN PWB, CRT SOCKET PWB PATTERN ..... 2-13

**CHANNEL CHART** ..... 2-15

## SEMICONDUCTOR SHAPES

### TRANSISTOR

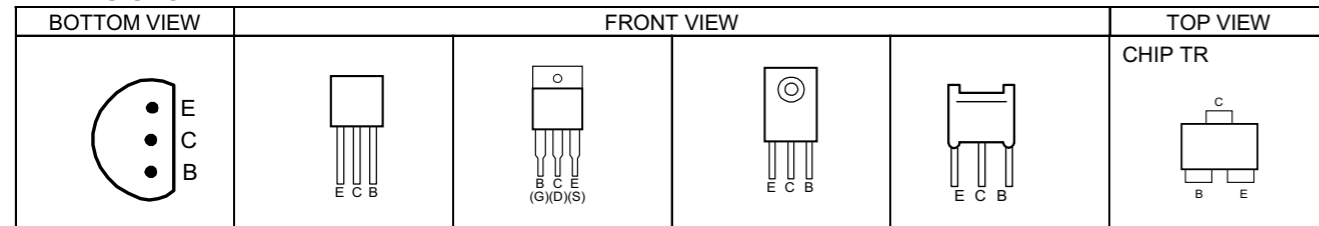

### IC

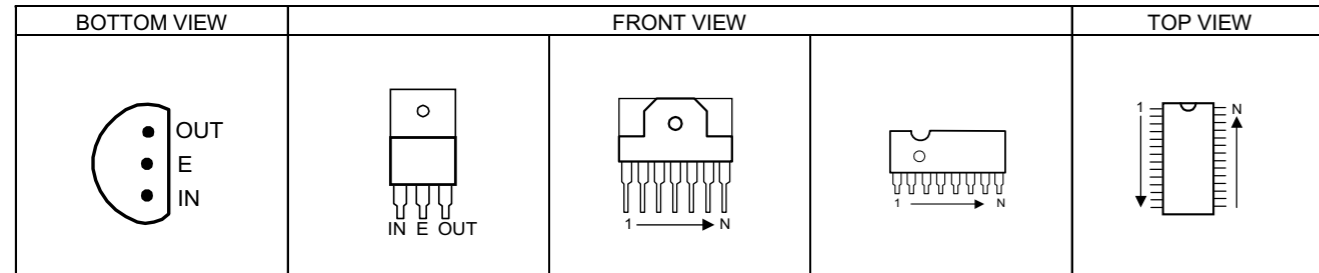

### CHIP IC

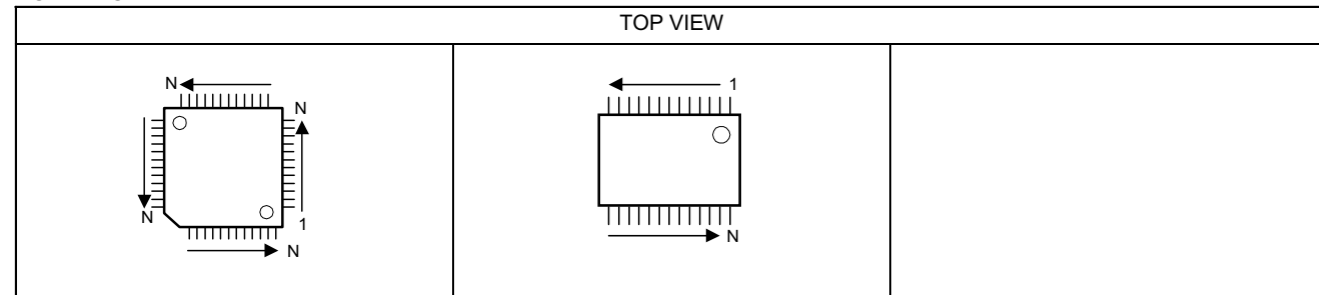

## CHANNEL CHART [US]

MODE		BAND	CHANNEL		TUNER BAND		
TV	CATV		REAL	DISP.			
○	○	VL	02	I			
			03				
			04				
			05				
			06				
		07	II				
	08						
	09						
	10						
	11						
	12						
	13						
	x	○	MID	A	14	I	
B				15			
C				16			
D				17			
E				18			
F				19			
G				20			
H				21			
I				22			
SUPER			II	J	23		
				K	24		
				L	25		
				M	26		
				N	27		
				O	28		
				P	29		
				Q	30		
				R	31		
				S	32		
				T	33		
				U	34		
				V	35		
				W	36		
				HYPER	IV	W+1	37
						W+2	38
						W+3	39
						W+4	40
						W+5	41
						W+6	42
						W+7	43
						W+8	44
						W+9	45
						W+10	46
						W+11	47
				ULTRA	IV	W+12	48
						W+13	49
						W+14	50
						W+15	51
						W+16	52
						W+17	53
						W+18	54
						W+19	55
						W+20	56
						W+21	57
						W+22	58
W+23			59				
W+24			60				
W+25			61				
W+26			62				
W+27			63				
W+28			64				
ULTRA			IV	W+29	65		
				W+30	66		
				W+31	67		
				W+32	68		
				W+33	69		
				W+34	70		

MODE		BAND	CHANNEL		TUNER BAND				
TV	CATV		REAL	DISP.					
x	○	ULTRA	W+35	71	IV				
			W+36	72					
			W+37	73					
			W+38	74					
			W+39	75					
			W+40	76					
			W+41	77					
			W+42	78					
			W+43	79					
			W+44	80					
			W+45	81					
			W+46	82					
			W+47	83					
			W+48	84					
			W+49	85					
			W+50	86					
			W+51	87					
			W+52	88					
			W+53	89					
			W+54	90					
			W+55	91					
			W+56	92					
			W+57	93					
			W+58	94					
			W+59	100					
			W+60	101					
			W+61	102					
			W+62	103					
			W+63	104					
			W+64	105					
			W+65	106					
			W+66	107					
			W+67	108					
			W+68	109					
			W+69	110					
			W+70	111					
			W+71	112					
			W+72	113					
			W+73	114					
			W+74	115					
			W+75	116					
			W+76	117					
			W+77	118					
			W+78	119					
			W+79	120					
			W+80	121					
			W+81	122					
			W+82	123					
			W+83	124					
			W+84	125					
			SUB MID	I		A-8	01		
						A-4	96		
						A-3	97		
						A-2	98		
			UHF	IV		14	69		
								TOTAL 180CH VHF 124CH UHF 56CH	
			NOTE: TO RECEIVE THE SUBSCRIPTION OR PREMIUM PROGRAMMING FROM CERTAIN CABLE COMPANIES. SPECIAL ADAPTERS MAY BE REQUIRED.						

# BLOCK DIAGRAM [C-20210]

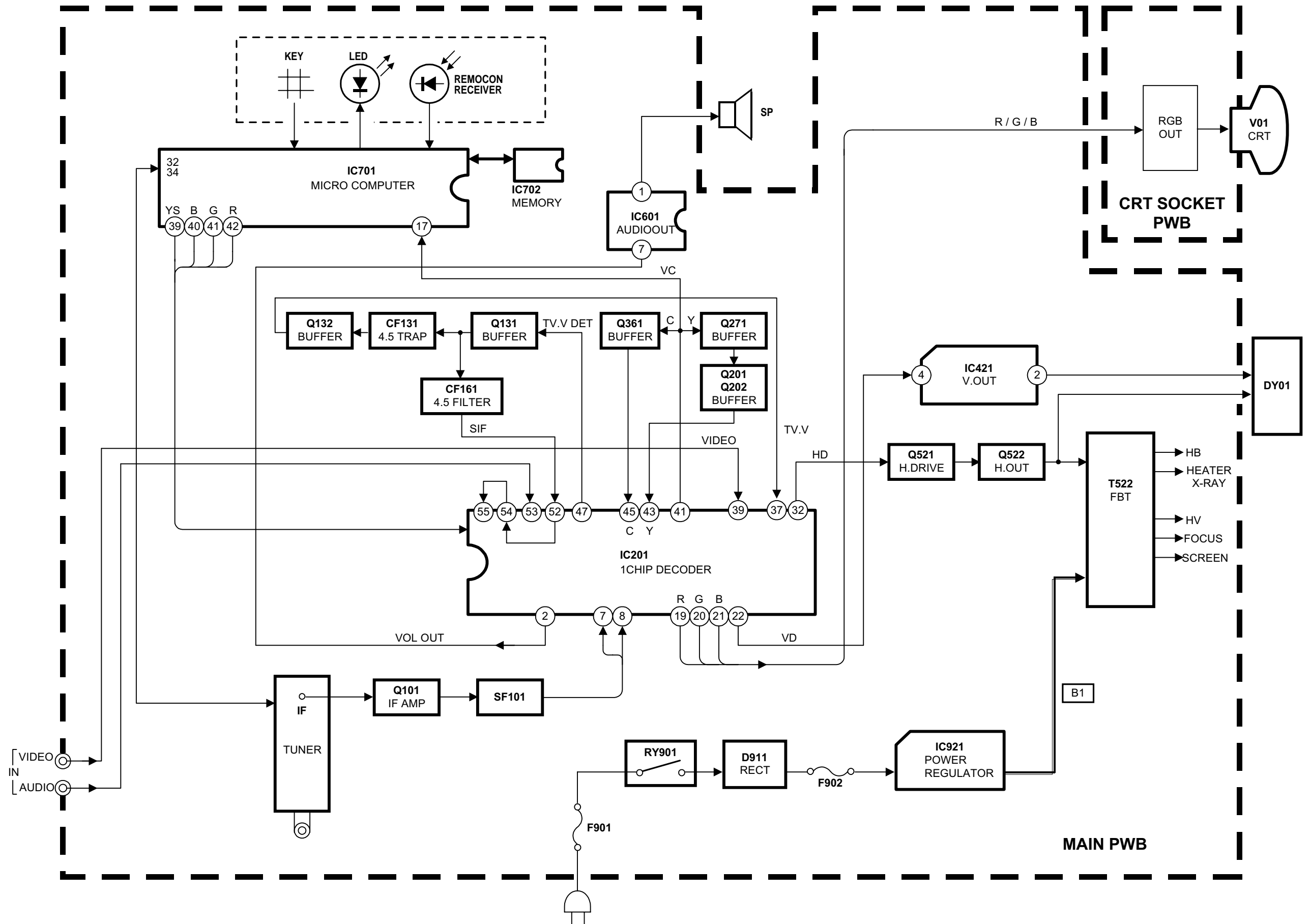

BLOCK DIAGRAM [AV-20220/AV-20221]

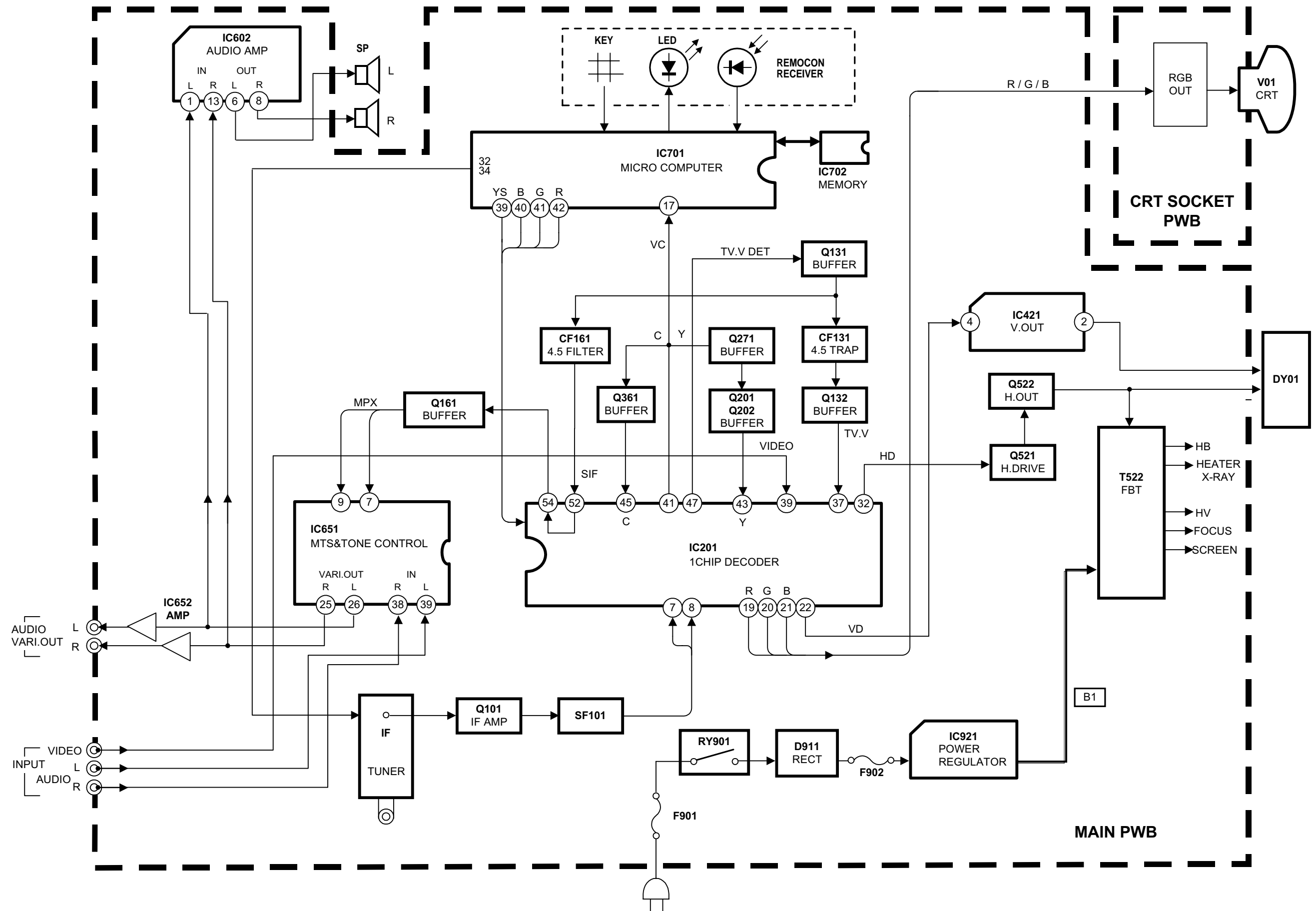

# CIRCUIT DIAGRAMS

## MAIN PWB CIRCUIT DIAGRAM

# C-20210

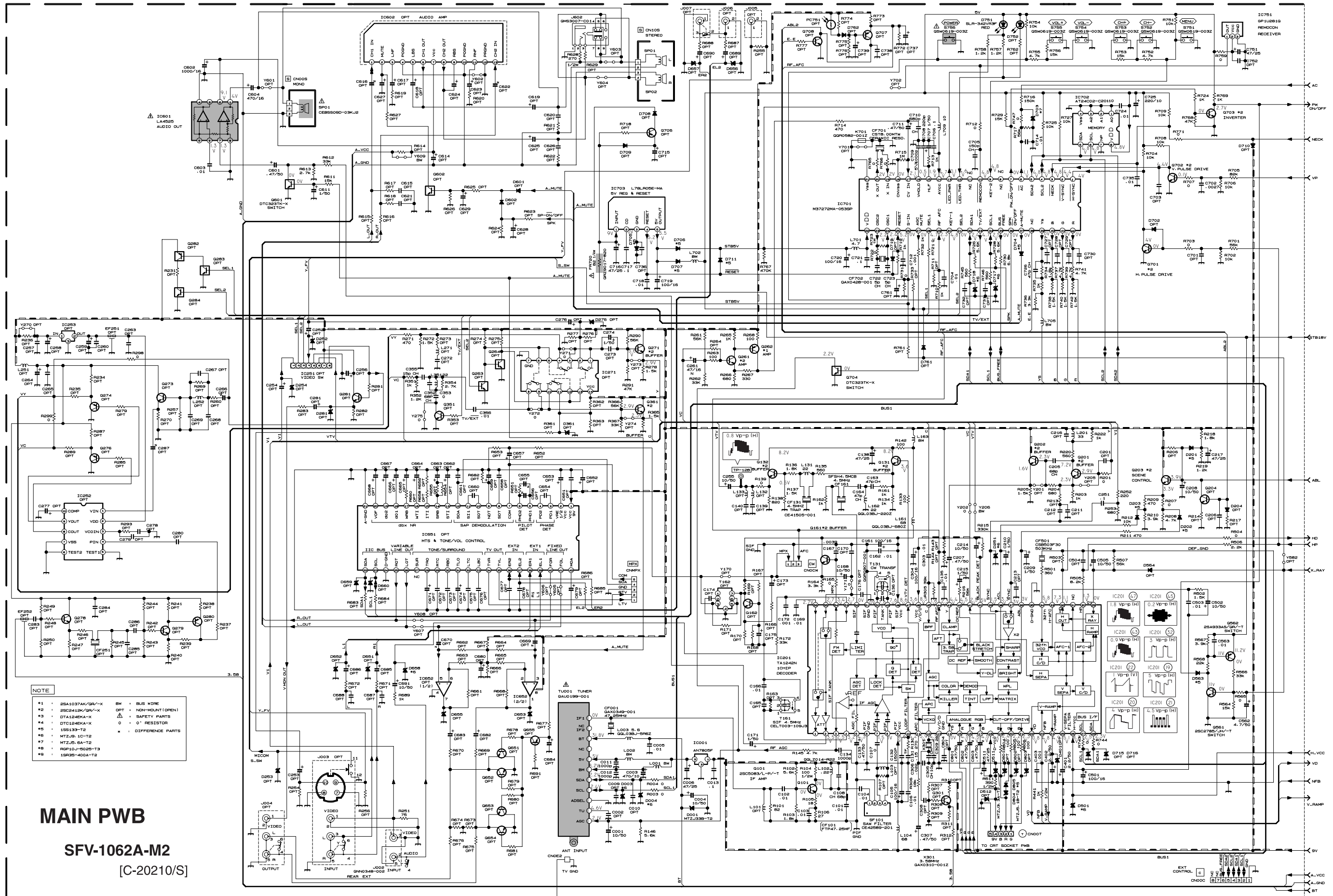

NOTE

#1	2SA1037AK/GR-X	BW	BUS WIRE
#2	2SC2418K/GR-X	OPT	NON-MOUNT (OPEN)
#3	DTAL2484K-X	Δ	SAFETY PARTS
#4	DTL12484K-X	0	0 RESISTOR
#5	1S9133-T2	.	DIFFERENCE PARTS
#6	MTZJ9.1C-T2		
#7	MTZJ5.6A-T2		
#8	RG10-5025-T3		
#9	1S9133-402A-T2		

**MAIN PWB**  
**SFV-1062A-M2**  
[C-20210/S]

MAIN PWB CIRCUIT DIAGRAM

AV-20220/AV-20221

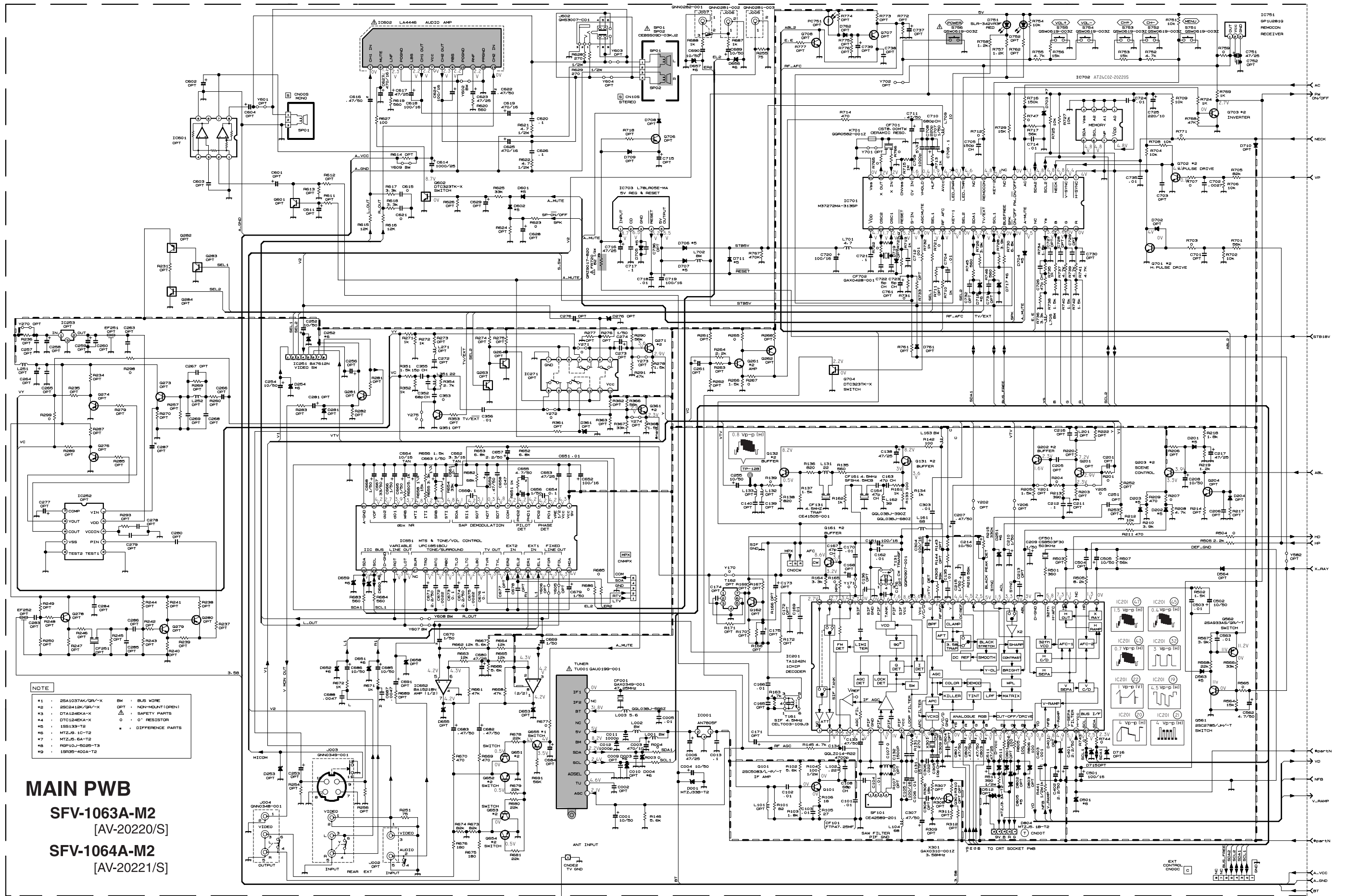

- NOTE**
- \*1 : 25A1037AK/GR-X      BW : BUS WIRE
  - \*2 : 25C2412K/GR-X      OPT : NON-MOUNT (OPEN)
  - \*3 : DT1246KA-X          O : RESISTOR
  - \*4 : DT1246KA-X          Δ : SAFETY PARTS
  - \*5 : 15S133-T2            \* : DIFFERENCE PARTS
  - \*6 : MTZJ5.1C-T2
  - \*7 : MTZJ5.6A-T2
  - \*8 : RGP10J-5025-T3
  - \*9 : 15R33-400A-T2

**MAIN PWB**  
**SFV-1063A-M2**  
 [AV-2020/S]  
**SFV-1064A-M2**  
 [AV-2021/S]



MAIN PWB, CRT SOCKET PWB CIRCUIT DIAGRAM

MAIN PWB

SFV-1062A-M2  
[C-20210/S]

SFV-1063A-M2  
[AV-20220/S]

SFV-1064A-M2  
[AV-20221/S]

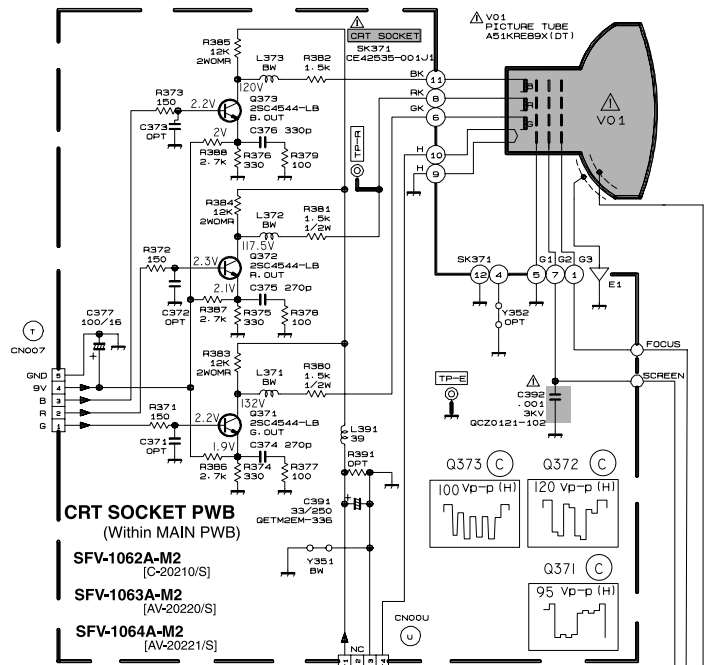
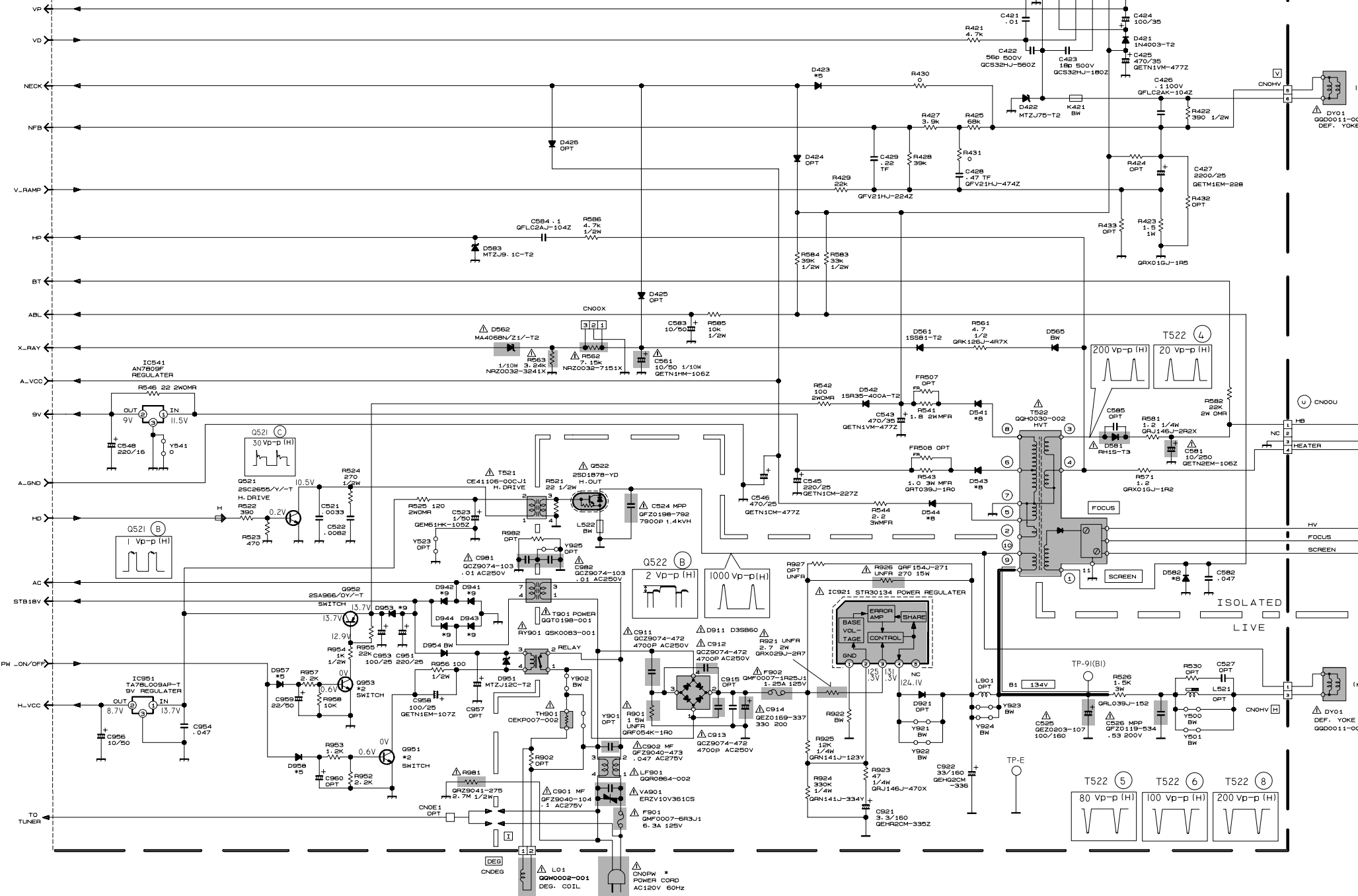

CRT SOCKET PWB  
(Within MAIN PWB)  
SFV-1062A-M2  
[C-20210/S]  
SFV-1063A-M2  
[AV-20220/S]  
SFV-1064A-M2  
[AV-20221/S]

\*DIFFERENCE LIST

POWER	SFV-1062A-M2	SFV-1063A-M2	SFV-1064A-M2
CN007	QMPD200	QMPD200	QMPD200
CN00U	200-JC1200-JC1200-JC	200-JC1200-JC1200-JC	200-JC1200-JC1200-JC

NOTE

- #1 : 2SA1037AK/OR/-X BW : BUS WIRE
- #2 : 2SC2412K/GR/-X OPT : NON-MOUNT (OPEN)
- #3 : DTA124EKA-X Δ : SAFETY PARTS
- #4 : DTC124EKA-X O : 0° RESISTOR
- #5 : 15B133-T2 \* : DIFFERENCE PARTS
- #6 : MTZJ9. 1C-T2
- #7 : MTZJ5. 6A-T2
- #8 : RGP10J-S025-T3
- #9 : 15R35-400A-T2

# PATTERN DIAGRAMS

MAIN PWB, CRT SOCKET PWB PATTERN

C-20210  
AV-20220  
AV-20221

C-20210  
AV-20220  
AV-20221

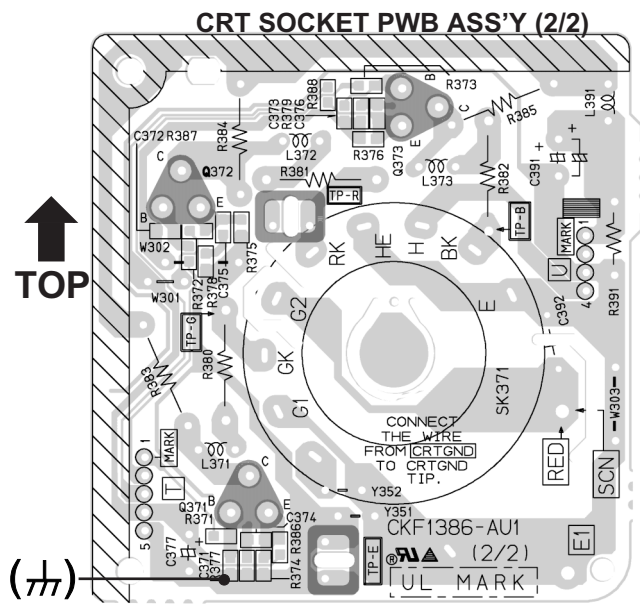

FRONT

MAIN PWB ASS'Y (1/2)

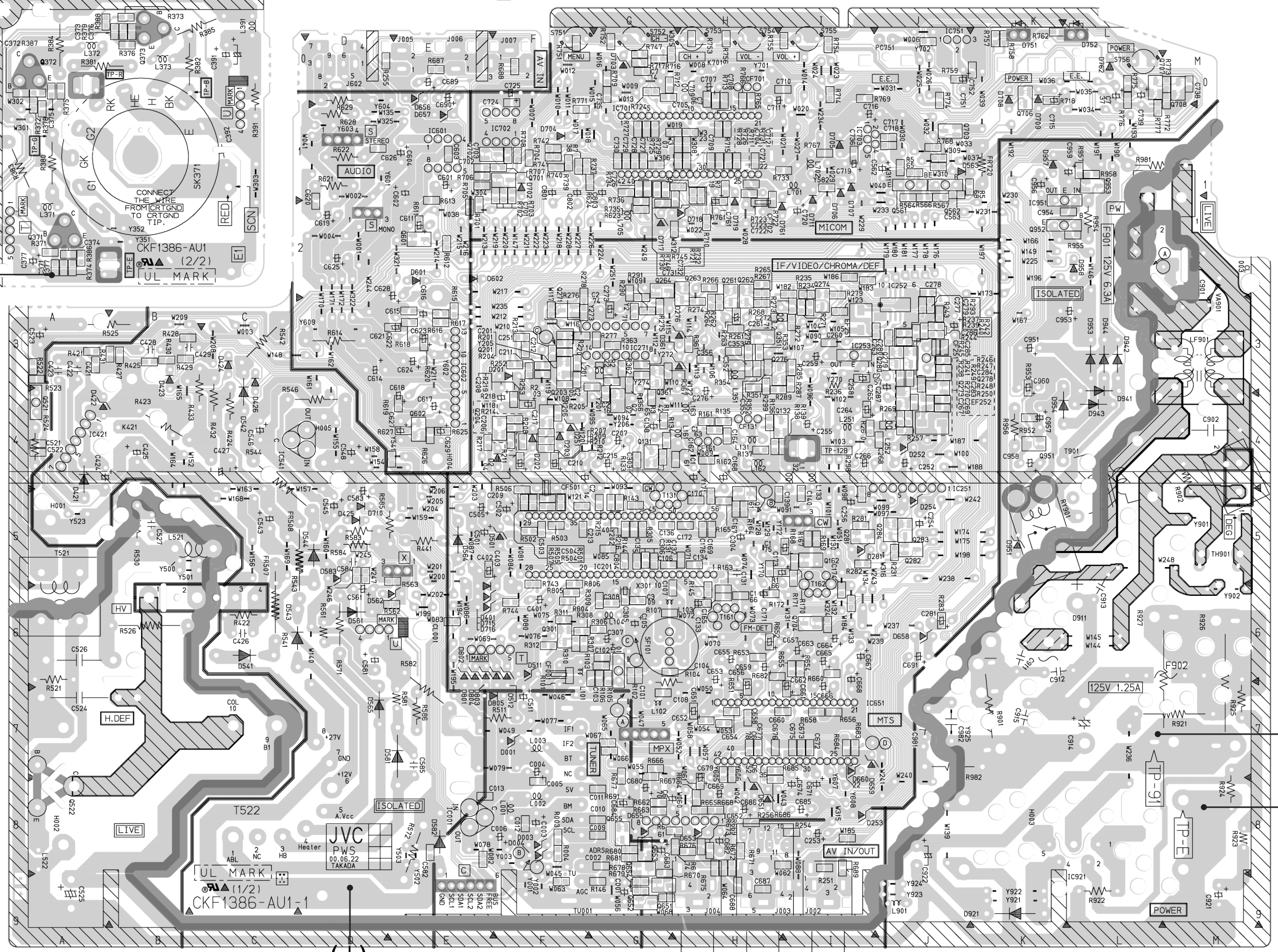

# JVC SERVICE & ENGINEERING COMPANY OF AMERICA

## DIVISION OF JVC AMERICAS CORP.

<b>Head office :</b>	1700 Valley Road, Wayne, New Jersey 07470	(973)315-5000
<b>East Coast :</b>	10 New Maple Avenue, Pine Brook, New Jersey 07058	(973)396-1000
<b>Midwest :</b>	705 Enterprise St. Aurora, Illinois 60504	(630)851-7855
<b>West Coast :</b>	5665 Corporate Avenue, Cypress, California 90630	(714)229-8011
<b>Southwest :</b>	10700 Hammerly, Suite 105, Houston, Texas 77043	(713)935-9331
<b>Hawaii :</b>	2969 Mapunapuna Place, Honolulu, Hawaii 96819	(808)833-5828
<b>Southeast :</b>	1500 Lakes Parkway, Lawrenceville, Georgia 30243	(770)339-2582

## JVC CANADA INC.

<b>Head office :</b>	21 Finchdene Square Scarborough, Ontario M1X 1A7	(416)293-1311
<b>Vancouver :</b>	13040 Worster Court Richmond B.C. V6V 2B3	(604)270-1311

# JVC®

# PARTS LIST

## CAUTION

- The parts identified by the  $\triangle$  symbol are important for the safety. Whenever replacing these parts, be sure to use specified ones to secure the safety .
- The parts not indicated in this Parts List and those which are filled with lines — in the Parts No. columns will not be supplied.
- P. W. Board Ass'y will not be supplied, but those which are filled with the Parts No. in the Parts No. columns will be supplied.

### ABBREVIATIONS OF RESISTORS, CAPACITORS AND TOLERANCES

RESISTORS		CAPACITORS	
C R	Carbon Resistor	C CAP.	Ceramic Capacitor
F R	Fusible Resistor	E CAP.	Electrolytic Capacitor
P R	Plate Resistor	M CAP.	Mylar Capacitor
V R	Variable Resistor	HV CAP.	High Voltage Capacitor
HV R	High Voltage Resistor	MF CAP.	Metalized Film Capacitor
MF R	Metal Film Resistor	MM CAP.	Metalized Mylar Capacitor
MG R	Metal Glazed Resistor	MP CAP.	Metalized Polystyrol Capacitor
MP R	Metal Plate Resistor	PP CAP.	Polypropylene Capacitor
OM R	Metal Oxide Film Resistor	PS CAP.	Polystyrol Capacitor
CMF R	Coating Metal Film Resistor	TF CAP.	Thin Film Capacitor
UNF R	Non-Flammable Resistor	MPP CAP.	Metalized Polypropylene Capacitor
CH V R	Chip Variable Resistor	TAN. CAP.	Tantalum Capacitor
CH MG R	Chip Metal Glazed Resistor	CH C CAP.	Chip Ceramic Capacitor
COMP. R	Composition Resistor	BP E CAP.	Bi-Polar Electrolytic Capacitor
LPTC R	Linear Positive Temperature Coefficient Resistor	CH AL E CAP.	Chip Aluminum Electrolytic Capacitor
		CH AL BP CAP.	Chip Aluminum Bi-Polar Capacitor
		CH TAN. E CAP.	Chip Tantalum Electrolytic Capacitor
		CH AL BP E CAP.	Chip Tantalum Bi-Polar Electrolytic Capacitor

TOLERANCES									
F	G	J	K	M	N	R	H	Z	P
±1%	±2%	±5%	±10%	±20%	±30%	+30% -10%	+50% -10%	+80% -20%	+100% -0%

## CONTENTS

### C-20210/s

■ EXPLODED VIEW PARTS LIST .....	26
■ EXPLODED VIEW .....	27
■ PRINTED WIRING BOARD PARTS LIST	
● MAIN PW BOARD ASS'Y (SFV-1062A-M2) [C-20210/S] (With CRT SOCKET PW BOARD) .....	28
■ REMOTE CONTROL UNIT PARTS LIST .....	32
■ PACKING .....	33
■ PACKING PARTS LIST .....	33

### AV-20220/s / AV-20221/s

■ EXPLODED VIEW PARTS LIST .....	34
■ EXPLODED VIEW .....	35
■ PRINTED WIRING BOARD PARTS LIST	
● MAIN PW BOARD ASS'Y (SFV-1063A-M2) [AV-20220/S] (With CRT SOCKET PW BOARD) .....	36
● MAIN PW BOARD ASS'Y (SFV-1064A-M2) [AV-20221/S] (With CRT SOCKET PW BOARD) .....	40
■ REMOTE CONTROL UNIT PARTS LIST .....	40
■ PACKING .....	41
■ PACKING PARTS LIST .....	41

## C-20210/s

### EXPLODED VIEW PARTS LIST

#### C-20210/s

△ Ref.No.	Part No.	Part Name	Description
△ V01	A51KRE89X(DT)	PICTURE TUBE	
△ DY01	QQD0011-001	DEF YOKE	
△ L01	QQW0002-001	DEG COIL	
△ T1522	QQH0030-002	H.V. TRANSF.	
1	CE42153-00AJ1	WEDGE ASSY	(×4)
2	CE42378-00B	P.C. MAGNET	
3	A48457-4-S	SPRING	
4	CHGB0016-0H	BRAIDED ASSY	
5	LC30191-001C-A	LENS	
6	LC30376-001A-A	POWER KNOB	
7	LC30271-001A-A	PUSH KNOB	
△ 8	CEB5509D-03KJ2	SPEAKER	SP01
9	CM48144-001-A	PB STOPPER	
△ 10	LC10108-002E-A	REAR COVER	
△ 11	QMPD200-200-JC	POWER CORD	CN10PW (Within MAIN PWB)
△ 12	LC20106-001D-A	CORD CLAMP	
13	QYSB5FG4016Z	TAPPING SCREW	(×5)
14	QYSB5B3010Z	TAPPING SCREW	
△ 15	LC31139-001A-A	RATING LABEL	
△ 16	LC10109-008A-A	FRONT CABINET	
17	CM43094-006-H	JVC MARK	

# EXPLODED VIEW

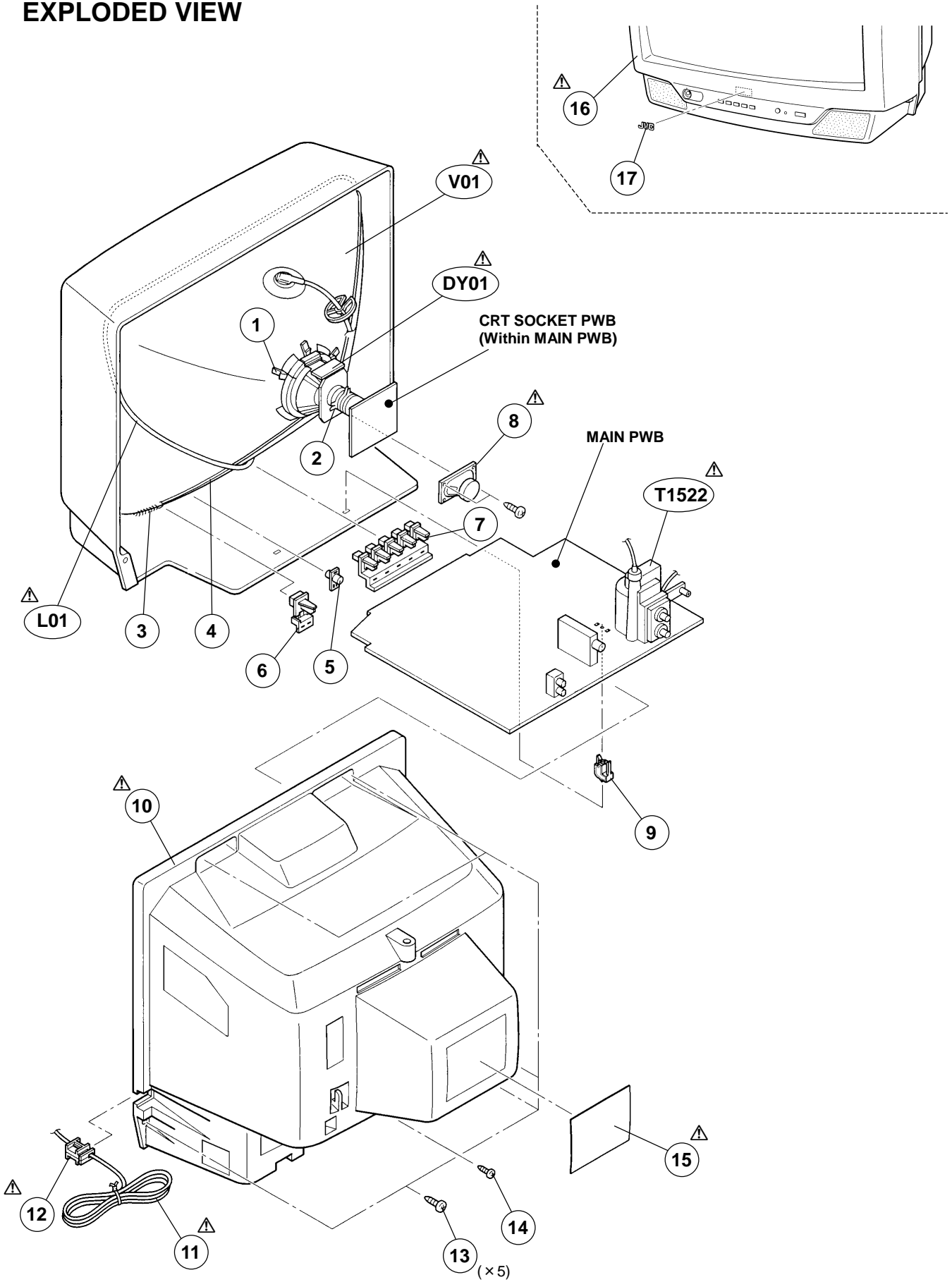

# PRINTED WIRING BOARD PARTS LIST

## MAIN P.W. BOARD ASS'Y (SFV-1062A-M2) [C-20210/s]

Symbol No.	Part No.	Part Name	Description
<b>RESISTOR</b>			
R1003-04	NRSA02J-0ROX	MG R	0.0Ω 1/10W J
R1101	NRSA02J-820X	MG R	82Ω 1/10W J
R1102	NRSA02J-562X	MG R	5.6kΩ 1/10W J
R1103	NRSA02J-182X	MG R	1.8kΩ 1/10W J
R1104	QRE121J-101Y	C R	100Ω 1/2W J
R1105	NRSA02J-180X	MG R	18Ω 1/10W J
R1106	NRSA02J-270X	MG R	27Ω 1/10W J
R1131	NRSA02J-271X	MG R	270Ω 1/10W J
R1133	NRSA02J-101X	MG R	100Ω 1/10W J
R1134	NRSA02J-102X	MG R	1kΩ 1/10W J
R1135	NRSA02J-561X	MG R	560Ω 1/10W J
R1136	NRSA02J-182X	MG R	1.8kΩ 1/10W J
R1137	NRSA02J-152X	MG R	1.5kΩ 1/10W J
R1138	NRSA02J-821X	MG R	820Ω 1/10W J
R1139	NRSA02J-0ROX	MG R	0.0Ω 1/10W J
R1142	NRSA02J-101X	MG R	100Ω 1/10W J
R1145	NRSA02J-472X	MG R	4.7kΩ 1/10W J
R1146	NRSA02J-562X	MG R	5.6kΩ 1/10W J
R1161-62	NRSA02J-102X	MG R	1kΩ 1/10W J
R1164	NRSA02J-332X	MG R	3.3kΩ 1/10W J
R1165	NRSA02J-0ROX	MG R	0.0Ω 1/10W J
R1172	NRSA02J-333X	MG R	33kΩ 1/10W J
R1201	NRSA02J-0ROX	MG R	0.0Ω 1/10W J
R1203	NRSA02J-102X	MG R	1kΩ 1/10W J
R1204	NRSA02J-681X	MG R	680Ω 1/10W J
R1205	NRSA02J-152X	MG R	1.5kΩ 1/10W J
R1207	NRSA02J-0ROX	MG R	0.0Ω 1/10W J
R1208	NRSA02J-472X	MG R	4.7kΩ 1/10W J
R1209	NRSA02J-471X	MG R	470Ω 1/10W J
R1210	NRSA02J-392X	MG R	3.9kΩ 1/10W J
R1211	NRSA02J-471X	MG R	470Ω 1/10W J
R1212	NRSA02J-103X	MG R	10kΩ 1/10W J
R1215	NRSA02J-334X	MG R	330kΩ 1/10W J
R1216	NRSA02J-563X	MG R	56kΩ 1/10W J
R1218	NRSA02J-182X	MG R	1.8kΩ 1/10W J
R1219	NRSA02J-122X	MG R	1.2kΩ 1/10W J
R1220	NRSA02J-561X	MG R	560Ω 1/10W J
R1222	NRSA02J-102X	MG R	1kΩ 1/10W J
R1251	NRSA02J-750X	MG R	75Ω 1/10W J
R1252	NRSA02J-221X	MG R	220Ω 1/10W J
R1253	NRSA02J-681X	MG R	680Ω 1/10W J
R1261	NRSA02J-563X	MG R	56kΩ 1/10W J
R1262	NRSA02J-333X	MG R	33kΩ 1/10W J
R1263	NRSA02J-101X	MG R	100Ω 1/10W J
R1265	NRSA02J-102X	MG R	1kΩ 1/10W J
R1266	NRSA02J-681X	MG R	680Ω 1/10W J
R1267	NRSA02J-331X	MG R	330Ω 1/10W J
R1268	NRSA02J-101X	MG R	100Ω 1/10W J
R1271	NRSA02J-471X	MG R	470Ω 1/10W J
R1272	NRSA02J-152X	MG R	1.5kΩ 1/10W J
R1278	NRSA02J-152X	MG R	1.5kΩ 1/10W J
R1290	NRSA02J-563X	MG R	56kΩ 1/10W J
R1291	NRSA02J-473X	MG R	47kΩ 1/10W J
R1298-99	NRSA02J-0ROX	MG R	0.0Ω 1/10W J
R1305	NRSA02J-393X	MG R	39kΩ 1/10W J
R1306	NRSA02J-183X	MG R	18kΩ 1/10W J
R1351	NRSA02J-102X	MG R	1kΩ 1/10W J
R1352	NRSA02J-122X	MG R	1.2kΩ 1/10W J
R1354	NRSA02J-272X	MG R	2.7kΩ 1/10W J
R1365	NRSA02J-152X	MG R	1.5kΩ 1/10W J
R1366	NRSA02J-563X	MG R	56kΩ 1/10W J
R1367	NRSA02J-333X	MG R	33kΩ 1/10W J
R1371-73	NRSA02J-151X	MG R	150Ω 1/10W J
R1374-76	NRSA02J-331X	MG R	330Ω 1/10W J
R1377-79	NRSA02J-101X	MG R	100Ω 1/10W J
R1380-82	QRZ0111-152	C R	1.5kΩ 1/2W K
R1383-85	QRL029J-123	OM R	12kΩ 2W J
R1386-88	NRSA02J-272X	MG R	2.7kΩ 1/10W J

Symbol No.	Part No.	Part Name	Description
<b>RESISTOR</b>			
R1421	NRSA02J-472X	MG R	4.7kΩ 1/10W J
R1422	QRE121J-391Y	C R	390Ω 1/2W J
R1423	QRX01GJ-1R5	MF R	1.5Ω 1W J
R1425	NRSA02J-683X	MG R	68kΩ 1/10W J
R1427	NRSA02J-392X	MG R	3.9kΩ 1/10W J
R1428	NRSA02J-393X	MG R	39kΩ 1/10W J
R1429	NRSA02J-223X	MG R	22kΩ 1/10W J
R1430-31	NRSA02J-0ROX	MG R	0.0Ω 1/10W J
R1441	QRE121J-102Y	C R	1kΩ 1/2W J
R1501	NRSA02J-361X	MG R	360Ω 1/10W J
R1502	NRSA02J-152X	MG R	1.5kΩ 1/10W J
R1504	NRSA02J-0ROX	MG R	0.0Ω 1/10W J
R1505	NRSA02J-822X	MG R	8.2kΩ 1/10W J
R1506	NRSA02J-222X	MG R	2.2kΩ 1/10W J
R1507	NRSA02J-563X	MG R	56kΩ 1/10W J
R1511	QRE121J-391Y	C R	390Ω 1/2W J
R1521	QRE121J-220Y	C R	22Ω 1/2W J
R1522	NRSA02J-391X	MG R	390Ω 1/10W J
R1523	NRSA02J-471X	MG R	470Ω 1/10W J
R1524	QRE121J-271Y	C R	270Ω 1/2W J
R1525	QRL029J-121	OM R	12Ω 2W J
R1526	QRL039J-152	OM R	1.5kΩ 3W J
R1541	QRT029J-1R8	MF R	1.8Ω 2W J
R1542	QRL029J-101	OM R	100Ω 2W J
R1543	QRT039J-1R0	MF R	1.0Ω 3W J
R1544	QRT039J-2R2	MF R	2.2Ω 3W J
R1546	QRL029J-220	OM R	22Ω 2W J
R1561	QRK126J-4R7X	C R	4.7Ω 1/2W J
R1562	NRZ0032-7151X	MF R	7.15kΩ 1/10W J
R1563	NRZ0032-3241X	MF R	3.24kΩ 1/10W J
R1564	NRSA02J-153X	MG R	15kΩ 1/10W J
R1565	NRSA02J-0ROX	MG R	0.0Ω 1/10W J
R1566	NRSA02J-333X	MG R	33kΩ 1/10W J
R1567	NRSA02J-392X	MG R	3.9kΩ 1/10W J
R1568	NRSA02J-223X	MG R	22kΩ 1/10W J
R1571	QRX01GJ-1R2	MF R	1.2Ω 1W J
R1581	QRJ146J-2R2X	C R	2.2Ω 1/4W J
R1582	QRL029J-223	OM R	22kΩ 2W J
R1583	QRE121J-333Y	C R	33kΩ 1/2W J
R1584	QRE121J-393Y	C R	39kΩ 1/2W J
R1585	QRE121J-103Y	C R	10kΩ 1/2W J
R1586	QRE121J-472Y	C R	4.7kΩ 1/2W J
R1611	NRSA02J-153X	MG R	15kΩ 1/10W J
R1612	NRSA02J-333X	MG R	33kΩ 1/10W J
R1613	NRSA02J-272X	MG R	2.7kΩ 1/10W J
R1628	QRE121J-271Y	C R	270Ω 1/2W J
R1689	NRSA02J-102X	MG R	1kΩ 1/10W J
R1701	NRSA02J-563X	MG R	56kΩ 1/10W J
R1702	NRSA02J-103X	MG R	10kΩ 1/10W J
R1703	NRSA02J-0ROX	MG R	0.0Ω 1/10W J
R1704	NRSA02J-103X	MG R	10kΩ 1/10W J
R1705	NRSA02J-823X	MG R	82kΩ 1/10W J
R1706	NRSA02J-103X	MG R	10kΩ 1/10W J
R1707	NRSA02J-0ROX	MG R	0.0Ω 1/10W J
R1708-09	NRSA02J-103X	MG R	10kΩ 1/10W J
R1710	NRSA02J-102X	MG R	1kΩ 1/10W J
R1712	NRSA02J-0ROX	MG R	0.0Ω 1/10W J
R1713	NRSA02J-102X	MG R	1kΩ 1/10W J
R1714	NRSA02J-471X	MG R	470Ω 1/10W J
R1715	NRSA02J-105X	MG R	1MΩ 1/10W J
R1716	NRSA02J-154X	MG R	150kΩ 1/10W J
R1717	NRSA02J-563X	MG R	56kΩ 1/10W J
R1719	NRSA02J-102X	MG R	1kΩ 1/10W J
R1721-22	NRSA02J-0ROX	MG R	0.0Ω 1/10W J
R1723	NRSA02J-105X	MG R	1MΩ 1/10W J
R1724	NRSA02J-102X	MG R	1kΩ 1/10W J
R1725	NRSA02J-103X	MG R	10kΩ 1/10W J
R1726	NRSA02J-562X	MG R	5.6kΩ 1/10W J

△ Symbol No. Part No. Part Name Description

**RESISTOR**

R1727	NRSA02J-103X	MG R	10kΩ 1/10W J
R1728	NRSA02J-562X	MG R	5.6kΩ 1/10W J
R1729	NRSA02J-153X	MG R	15kΩ 1/10W J
R1730	NRSA02J-682X	MG R	6.8kΩ 1/10W J
R1731	NRSA02J-0R0X	MG R	0.0Ω 1/10W J
R1732	NRSA02J-102X	MG R	1kΩ 1/10W J
R1734	NRSA02J-182X	MG R	1.8kΩ 1/10W J
R1735	NRSA02J-102X	MG R	1kΩ 1/10W J
R1736	NRSA02J-332X	MG R	3.3kΩ 1/10W J
R1737	NRSA02J-472X	MG R	4.7kΩ 1/10W J
R1738	NRSA02J-152X	MG R	1.5kΩ 1/10W J
R1739	NRSA02J-472X	MG R	4.7kΩ 1/10W J
R1740	NRSA02J-152X	MG R	1.5kΩ 1/10W J
R1741	NRSA02J-472X	MG R	4.7kΩ 1/10W J
R1742	NRSA02J-152X	MG R	1.5kΩ 1/10W J
R1743-44	NRSA02J-0R0X	MG R	0.0Ω 1/10W J
R1745-46	NRSA02J-561X	MG R	560Ω 1/10W J
R1747	NRSA02J-0R0X	MG R	0.0Ω 1/10W J
R1751	NRSA02J-103X	MG R	10kΩ 1/10W J
R1752	NRSA02J-472X	MG R	4.7kΩ 1/10W J
R1753	NRSA02J-153X	MG R	15kΩ 1/10W J
R1754	NRSA02J-103X	MG R	10kΩ 1/10W J
R1755	NRSA02J-472X	MG R	4.7kΩ 1/10W J
R1756	NRSA02J-153X	MG R	15kΩ 1/10W J
R1757-58	NRSA02J-122X	MG R	1.2kΩ 1/10W J
R1759	NRSA02J-0R0X	MG R	0.0Ω 1/10W J
R1765-66	NRSA02J-0R0X	MG R	0.0Ω 1/10W J
R1767	NRSA02J-474X	MG R	470kΩ 1/10W J
R1768	NRSA02J-473X	MG R	47kΩ 1/10W J
R1769	NRSA02J-102X	MG R	1kΩ 1/10W J
R1771	NRSA02J-0R0X	MG R	0.0Ω 1/10W J
R1804-06	NRSA02J-101X	MG R	100Ω 1/10W J
△ R1901	QRFO54K-1R0	UNF R	1.0 Ω 5W K
△ R1921	QRX029J-2R7	MF R	2.7 Ω 2W J
R1923	QRJ146J-470X	C R	47Ω 1/4W J
R1924	QRN141J-334Y	C R	330kΩ 1/4W J
R1925	QRN141J-123Y	C R	12kΩ 1/4W J
△ R1926	QRF154J-271	UNF R	270 Ω 15W J
R1952	NRSA02J-222X	MG R	2.2kΩ 1/10W J
R1953	NRSA02J-122X	MG R	1.2kΩ 1/10W J
R1954	QRE121J-102Y	C R	1kΩ 1/2W J
R1955	NRSA02J-223X	MG R	22kΩ 1/10W J
R1956	QRE121J-101Y	C R	100Ω 1/2W J
R1957	NRSA02J-222X	MG R	2.2kΩ 1/10W J
R1958	NRSA02J-103X	MG R	10kΩ 1/10W J
△ R1981	QRZ9041-275	C R	2.7M 1/2W K

**CAPACITOR**

C1001	QETN1HM-106Z	E CAP.	10μF 50V M
C1003	QETN1AM-477Z	E CAP.	470μF 10V M
C1004	QETN1HM-106Z	E CAP.	10μF 50V M
C1005	NCB21HK-103X	C CAP.	0.01μF 50V K
C1006	QETN1EM-476Z	E CAP.	47μF 25V M
C1011-12	NCB21HK-102X	C CAP.	1000pF 50V K
C1013	NCB21HK-104X	CHIP CAP.	0.1μF 50V K
C1101-04	NCB21HK-103X	C CAP.	0.01μF 50V K
C1105	QETN1CM-107Z	E CAP.	100μF 16V M
C1106	NCB21HK-103X	C CAP.	0.01μF 50V K
C1107	NRSA02J-0R0X	MG R	0.0Ω 1/10W J
C1108	NDC21HJ-680X	C CAP.	68pF 50V J
C1131	QFV71HJ-154Z	MF CAP.	0.15μF 50V J
C1132	NCB21HK-152X	C CAP.	1500pF 50V K
C1133	QETN1HM-474Z	E CAP.	0.47μF 50V M
C1134	NCB21HK-102X	C CAP.	1000pF 50V K
C1135	NCB21HK-103X	C CAP.	0.01μF 50V K
C1138	QETN1EM-476Z	E CAP.	47μF 25V M
C1161	QETN1CM-107Z	E CAP.	100μF 16V M
C1162	NCB21HK-103X	C CAP.	0.01μF 50V K
C1163-64	NDC21HJ-470X	C CAP.	47pF 50V J
C1166	NCB21HK-103X	C CAP.	0.01μF 50V K
C1167	NCB21HK-392X	C CAP.	3900pF 50V K
C1168	QETN1HM-106Z	E CAP.	10μF 50V M

△ Symbol No. Part No. Part Name Description

**CAPACITOR**

C1169	NCB21HK-103X	C CAP.	0.01μF 50V K
C1171	QETN1HM-105Z	E CAP.	1μF 50V M
C1172	NCB21HK-102X	C CAP.	1000pF 50V K
C1205	NDC21HJ-680X	C CAP.	68pF 50V J
C1207	QETN1HM-474Z	E CAP.	0.47μF 50V M
C1208	QETN1HM-106Z	E CAP.	10μF 50V M
C1209-10	QETN1HM-105Z	E CAP.	1μF 50V M
C1212	NCB21HK-104X	CHIP CAP.	0.1μF 50V K
C1214	QETN1HM-106Z	E CAP.	10μF 50V M
C1215	QETN1HM-105Z	E CAP.	1μF 50V M
C1217	QETN1EM-476Z	E CAP.	47μF 25V M
C1251	NCB21HK-104X	CHIP CAP.	0.1μF 50V K
C1255	QETN1HM-106Z	E CAP.	10μF 50V M
C1261	QENC1CM-476Z	BP E CAP.	47μF 16V M
C1274	QETN1HM-105Z	E CAP.	1μF 50V M
C1303	NCB21HK-103X	C CAP.	0.01μF 50V K
C1304	QETN1CM-107Z	E CAP.	100μF 16V M
C1305	NDC21HJ-100X	C CAP.	10pF 50V J
C1306	NCB21HK-223X	C CAP.	0.022μF 50V K
C1307	QETN1HM-474Z	E CAP.	0.47μF 50V M
C1309	NDC21HJ-2R0X	C CAP.	2.0pF 50V J
C1352	NDC21HJ-680X	C CAP.	68pF 50V J
C1353	NRSA02J-0R0X	MG R	0.0Ω 1/10W J
C1355	NDC21HJ-150X	C CAP.	15pF 50V J
C1356	NCB21HK-103X	C CAP.	0.01μF 50V K
C1374-75	NCS21HJ-271X	C CAP.	270pF 50V J
C1376	NCS21HJ-331X	C CAP.	330pF 50V J
C1377	QETN1CM-107Z	E CAP.	100μF 16V M
△ C1391	QETM2EM-336	E CAP.	33μF 250V M
C1392	QCZ0121-102	C CAP.	1000pF 3kV Z
C1401	QETN1HM-225Z	E CAP.	2.2μF 50V M
C1402	QBHC1CK-225Z	TAN. CAP.	2.2μF 16V K
C1403	NCB21HK-102X	C CAP.	1000pF 50V K
C1421	NCB21HK-103X	C CAP.	0.01μF 50V K
C1422	QCS32HJ-560Z	C CAP.	56pF 500V J
C1423	QCS32HJ-180Z	C CAP.	18pF 500V J
C1424	QETN1VM-107Z	E CAP.	100μF 35V M
C1425	QETN1VM-477Z	E CAP.	470μF 35V M
C1426	QFLC2AK-104Z	M CAP.	0.1μF 100V K
C1427	QETN1EM-228	E CAP.	2200μF 25V M
C1428	QFV21HJ-474Z	MF CAP.	0.47μF 50V J
C1429	QFV21HJ-224Z	MF CAP.	0.22μF 50V J
C1501	QETN1CM-107Z	E CAP.	100μF 16V M
C1502	QETN1HM-106Z	E CAP.	10μF 50V M
C1503	NCB21HK-103X	C CAP.	0.01μF 50V K
C1505	QETN1HM-106Z	E CAP.	10μF 50V M
C1511	QETN1EM-476Z	E CAP.	47μF 25V M
C1521	NCB21HK-332X	C CAP.	3300pF 50V K
C1522	NCB21HK-822X	C CAP.	8200pF 50V K
C1523	QEM61HK-105Z	E CAP.	1μF 50V K
△ C1524	QFZ0198-79Z	MPP CAP.	7900pF1.4kVH±2.5%
△ C1525	QEZO203-107	E CAP.	100μF 160V M
△ C1526	QFZO119-534	MPP CAP.	0.53μF 200V ±3%
C1543	QETN1VM-477Z	E CAP.	470μF 35V M
C1545	QETN1CM-227Z	E CAP.	220μF 16V M
C1546	QETN1CM-477Z	E CAP.	470μF 16V M
C1548	QETN1CM-227Z	E CAP.	220μF 16V M
△ C1561	QETN1HM-106Z	E CAP.	10μF 50V M
C1562	QETN1HM-475Z	E CAP.	4.7μF 50V M
C1563	NCB21HK-103X	C CAP.	0.01μF 50V K
△ C1581	QETN2EM-106Z	E CAP.	10μF 250V M
C1582	NCB21HK-473X	C CAP.	0.047μF 50V K
C1583	QETN1HM-106Z	E CAP.	10μF 50V M
C1584	QFLC2AJ-104Z	M CAP.	0.1μF 100V J
C1601	QETN1HM-474Z	E CAP.	0.47μF 50V M
C1602	QETN1CM-108Z	E CAP.	1000pF 16V M
C1603	NCB21HK-103X	C CAP.	0.01μF 50V K
C1604	QETN1CM-477Z	E CAP.	470μF 16V M
C1611	QETN1HM-105Z	E CAP.	1μF 50V M
C1691	QETN1HM-106Z	E CAP.	10μF 50V M
C1702	NCB21HK-272X	C CAP.	2700pF 50V K
C1704	NCB21HK-103X	C CAP.	0.01μF 50V K
C1705	NDC21HJ-151X	C CAP.	150pF 50V J



△ Symbol No.	Part No.	Part Name	Description
<b>CAPACITOR</b>			
C1706	NCB21HK-104X	CHIP CAP.	0.1μF 50V K
C1707	QETN1HM-105Z	E CAP.	1μF 50V M
C1708	NCS21HJ-221X	C CAP.	220pF 50V J
C1709	NCS21HJ-102X	C CAP.	1000pF 50V J
C1710	NDC21HJ-681X	C CAP.	680pF 50V J
C1711	QETN1HM-474Z	E CAP.	0.47μF 50V M
C1712	NCB21HK-102X	C CAP.	1000pF 50V K
C1714	NCB21HK-103X	C CAP.	0.01μF 50V K
C1716	QETN1EM-476Z	E CAP.	47μF 25V M
C1717	NCB21HK-104X	CHIP CAP.	0.1μF 50V K
C1718	NCB21HK-103X	C CAP.	0.01μF 50V K
C1719-20	QETN1CM-107Z	E CAP.	100μF 16V M
C1721	NCB21HK-104X	CHIP CAP.	0.1μF 50V K
C1722-23	NDC21HJ-5R0X	C CAP.	5.0pF 50V J
C1724	NCB21HK-103X	C CAP.	0.01μF 50V K
C1725	QETN1AM-227Z	E CAP.	220μF 10V M
C1726	NDC21HJ-470X	C CAP.	47pF 50V J
C1735	NCB21HK-103X	C CAP.	0.01μF 50V K
C1751	QETN1EM-476Z	E CAP.	47μF 25V M
C1801-03	QENC1HM-474Z	BP E CAP.	0.47μF 50V M
△ C1901	QFZ9040-104	MF CAP.	0.1μFAC275V M
△ C1902	QFZ9040-473	MF CAP.	0.047μFAC275V M
△ C1911	QCZ9074-472	C CAP.	4700pFAC250V M
△ C1912	QCZ9074-472	C CAP.	4700pFAC250V M
△ C1913	QCZ9074-472	C CAP.	4700pFAC250V M
△ C1914	QEZ0169-337	E CAP.	330μF 200V M
C1921	QEHRC2M-335Z	E CAP.	3.3μF 160V M
C1951	QETN1EM-227Z	E CAP.	220μF 25V M
C1953	QETN1EM-107Z	E CAP.	100μF 25V M
C1954	NCB21HK-473X	C CAP.	0.047μF 50V K
C1956	QETN1HM-106Z	E CAP.	10μF 50V M
C1958	QETN1EM-107Z	E CAP.	100μF 25V M
C1959	QETN1HM-226Z	E CAP.	22μF 50V M
△ C1981	QCZ9074-103	C CAP.	0.01μFAC250V M
△ C1982	QCZ9074-103	C CAP.	0.01μFAC250V M
<b>TRANSFORMER</b>			
T1131	QQR0907-001	I. F. TRANSFORMER	
T1161	CEL1003-109J3	S. I. F. TRANSF.	
△ T1521	CE41106-00CJ1	DRIVE TRANSF.	
△ T1522	QQH0030-002	H. V. TRANSF.	
△ T1901	QQT0198-001	POWER TRANSF.	
<b>COIL</b>			
L1003	QQL03BJ-5R6Z	PEAKING COIL	
L1102	QQLZ014-R22	PEAKING COIL	0.22μH
L1104	QQL03BJ-680Z	PEAKING COIL	
L1131	QQL03BJ-220Z	PEAKING COIL	
L1161	QQL03BJ-680Z	PEAKING COIL	
L1162	QQL03BJ-220Z	PEAKING COIL	
L1201	QQL03BJ-330Z	PEAKING COIL	33μH
L1351	QQL03BJ-220Z	PEAKING COIL	
L1391	QQL03BJ-390Z	PEAKING COIL	
L1701	QQL03BJ-4R7Z	PEAKING COIL	
L1709	QQL03BJ-100Z	PEAKING COIL	
<b>DIODE</b>			
D1001	MTZJ33B-T2	ZENER DIODE	
D1003-04	MTZJ9.1C-T2	ZENER DIODE	
D1201-03	1SS133-T2	SI. DIODE	
D1251	MTZJ9.1C-T2	ZENER DIODE	
D1421	1N4003-T2	SI. DIODE	
D1422	MTZJ75-T2	ZENER DIODE	
D1423	1SS133-T2	SI. DIODE	
D1501	MTZJ9.1C-T2	ZENER DIODE	
D1511	MTZJ3.3A-T2	ZENER DIODE	
D1541	RGPI0J-5025-T3	SI. DIODE	
D1542	1SR35-400A-T2	SI. DIODE	
D1543-44	RGPI0J-5025-T3	SI. DIODE	
D1561	1SS81-T2	SI. DIODE	
△ D1562	MA4068N/Z1/-T2	ZENER DIODE	
D1563	1SS133-T2	SI. DIODE	

△ Symbol No.	Part No.	Part Name	Description
<b>DIODE</b>			
△ D1581	RH1S-T3	SI. DIODE	
D1582	RGPI0J-5025-T3	SI. DIODE	
D1583	MTZJ9.1C-T2	ZENER DIODE	
D1658	MTZJ9.1C-T2	ZENER DIODE	
D1703	MTZJ5.6A-T2	ZENER DIODE	
D1704-07	1SS133-T2	SI. DIODE	
D1711	1SS133-T2	SI. DIODE	
D1717-18	MTZJ9.1C-T2	ZENER DIODE	
D1751	SLR-342VR3F	L. E. D.	
D1804	MTZJ5.1B-T2	ZENER DIODE	
D1805	1SS133-T2	SI. DIODE	
△ D1911	D3SB60	BRIDGE DIODE	
D1941-44	1SR35-400A-T2	SI. DIODE	
D1951	MTZJ12C-T2	ZENER DIODE	
D1953	1SR35-400A-T2	SI. DIODE	
D1957-58	1SS133-T2	SI. DIODE	
<b>TRANSISTOR</b>			
Q1101	2SC5083/L-P/-T	SI. TRANSISTOR	
Q1131-32	2SC2412K/QR/-X	SI. TRANSISTOR	
Q1161	2SC2412K/QR/-X	SI. TRANSISTOR	
Q1201-03	2SC2412K/QR/-X	SI. TRANSISTOR	
Q1261	2SC2412K/QR/-X	SI. TRANSISTOR	
Q1262	2SA1037AK/QR/-X	SI. TRANSISTOR	
Q1271	2SC2412K/QR/-X	SI. TRANSISTOR	
Q1361	2SC2412K/QR/-X	SI. TRANSISTOR	
Q1371-73	2SC4544-LB	SI. TRANSISTOR	
Q1521	2SC2655/Y/-T	SI. TRANSISTOR	
△ Q1522	2SD1878-YD	SI. TRANSISTOR	H. OUT
Q1561	2SC2785/JH/-T	SI. TRANSISTOR	
Q1562	2SA933AS/QR/-T	SI. TRANSISTOR	
Q1601	DTC323TK-X	DIGI. TRANSISTOR	
Q1701-03	2SC2412K/QR/-X	SI. TRANSISTOR	
Q1704	DTC323TK-X	DIGI. TRANSISTOR	
Q1951	2SC2412K/QR/-X	SI. TRANSISTOR	
Q1952	2SA966/OY/-T	SI. TRANSISTOR	
Q1953	2SC2412K/QR/-X	SI. TRANSISTOR	
<b>IC</b>			
IC1001	AN7805F	I. C. (MONO-ANA)	
IC1201	TA1242N	I. C. (MONO-ANA)	
△ IC1421	LA7830	I. C. (MONO-ANA)	
IC1541	AN7809F	I. C. (MONO-ANA)	
△ IC1601	LA4525	I. C. (MONO-ANA)	
IC1701	M37272MA-053SP	I. C. (MICRO-COMP)	
IC1702	AT24C02-C20110	I. C.	(SERVICE)
IC1703	L78L05E-MA	I. C. (MONO-ANA)	
IC1751	GP1U281Q	IFR DETECT UNIT	
△ IC1921	STR30134	I. C. (H)	
IC1951	TA78L009AP-T	I. C. (MONO-ANA)	
<b>OTHERS</b>			
CF1001	LC30190-001B-A	LED HOLDER	
CF1131	QAX0349-001	CERAMIC FILTER	
CF1161	CE41505-001	CERAMIC FILTER	
CF1501	SFSH4.5MBC	CERAMIC FILTER	
CF1701	CSB503F30-T2	CER. RESONATOR	
CF1702	CST8.00MTW	CER. RESONATOR	
CF1703	QAX0428-001	CER. RESONATOR	
CL1001	QZW0028-002	WIRE CLAMP	
CL1003	QZW0028-001	WIRE CLAMP	
△ CN10PW	QMPD200-200-JC	POWER CORD	(Charcoal type)
△ F1901	QMF0007-6R3J1	FUSE	6.3A
△ F1902	QMF0007-1R25J1	FUSE	1.25A
FC1901	CEMG002-001Z	FUSE CLIP	(x2)
FC1902	CEMG002-001Z	FUSE CLIP	(x4)
△ FR1720	QRZ9017-820	F R	82 Ω 1/4W J
J1002	QNN0348-002	PIN JACK	
J1602	QNS0155-001	JACK	
K1701	QQR0582-001Z	BEADS CORE	
△ LF1901	QQR0864-002	LINE FILTER	
△ RY1901	QSK0083-001	RELAY	
S1751	QSW0619-003Z	PUSH SWITCH	MENU

△ Symbol No.	Part No.	Part Name	Description
<b>OTHERS</b>			
S1752	QSW0619-003Z	PUSH SWITCH	CH-
S1753	QSW0619-003Z	PUSH SWITCH	CH+
S1754	QSW0619-003Z	PUSH SWITCH	VOL-
S1755	QSW0619-003Z	PUSH SWITCH	VOL+
△ S1756	QSW0619-003Z	PUSH SWITCH	POWER
SF1101	CE42589-201	SAW FILTER	
△ SK1371	CE42535-001J1	C. R. T. SOCKET	
△ TH1901	CEKP007-002	P. THERMISTOR	
△ TU1001	QAU0199-001	TUNER	
△ VA1901	ERZV10V361CS	VARISTOR	
X1301	QAX0310-001Z	CRYSTAL	

## REMOTE CONTROL UNIT PARTS LIST (RM-C205-1C)

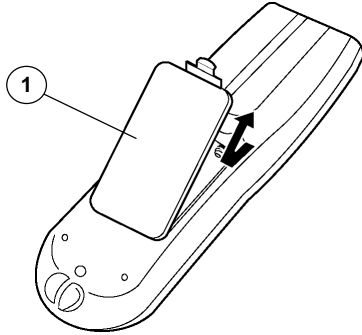

<b>C-20210/S Charcoal Model</b>			
<b>△ Ref.No.</b>	<b>Part No.</b>	<b>Part Name.</b>	<b>Description</b>
1	511A24001	BATTERY COVER	(RM-C205-1C)

## PACKING

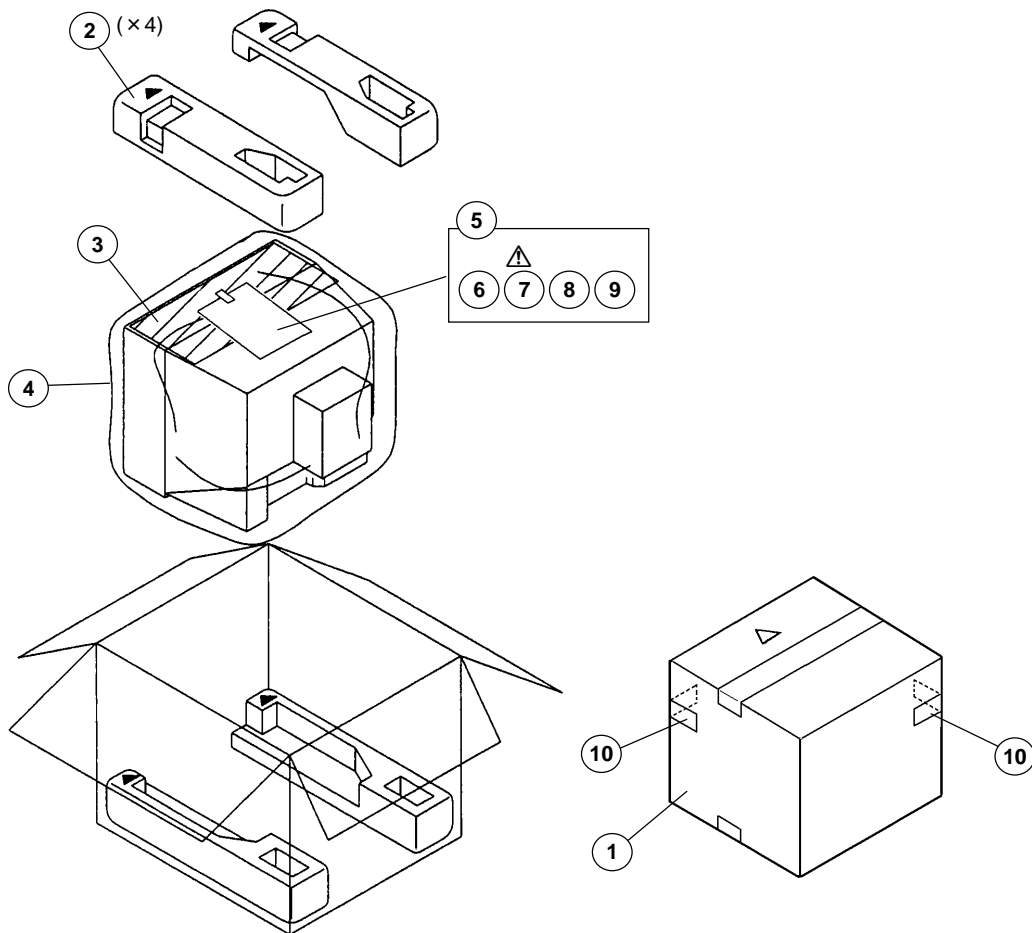

## PACKING PARTS LIST

△ Ref.No.	Part No.	Part Name	Description
1	GQ10009-010A-A	PACKING CASE	
2	LC10116-002A-A	CUSHION ASSY	4pcs in 1set
3	CP30055-001-A	TOP COVER	
4	CP30056-009-A	POLY BAG	
5	QPA02503505	POLY BAG	
6	RM-C205-1C	REMOCON UNIT	
△ 7	LCT0948-001A-A	INST. BOOK	
8	BT-51020-1Q	REGISTER CARD	
9	BT-52004-1Q	WARRANTY CARD	
10	CM36616-001-A	CORNER LABEL	2pcs in 1set

## AV-20220/s / AV-20221/s

### EXPLODED VIEW PARTS LIST

#### AV-20220/s Charcoal Model

△ Ref.No.	Part No.	Part Name	Description
△ V01	A51KRE89X(DT)	PICTURE TUBE	
△ DY01	QQD0011-001	DEF YOKE	
△ L01	QQW0002-001	DEG COIL	
△ T1522	QQH0030-002	H.V.TRANSF.	
1	CE42153-00AJ1	WEDGE ASSY	(×4)
2	CE42378-00B	P.C.MAGNET	
3	A48457-4-S	SPRING	
4	CHGB0016-0H	BRAIDED ASSY	
5	LC30191-001C-A	LENS	
6	LC30376-001A-A	POWER KNOB	
7	LC30271-001A-A	PUSH KNOB	
△ 8	CEBSS09D-03KJ2	SPEAKER	(×2)SP01,SP02
9	CM48144-001-A	PB STOPPER	
△ 10	LC10108-001E-A	REAR COVER	
△ 11	QMPD200-200-JC	POWER CORD	CN10PW (Within MAIN PWB)
△ 12	LC20106-001D-A	POWER CORD CLAMP	
13	QYSB5FG4016Z	TAPPING SCREW	(×5)
14	QYSBSB3010Z	TAPPING SCREW	(×2)
△ 15	LC31139-001A-A	RATING LABEL	
△ 16	LC10109-016A-A	FRONT CABINET	
17	CM43094-006-H	JVC MARK	

#### AV-20221/s White Model

△ Ref.No.	Part No.	Part Name	Description
△ V01	A51KRE89X(DT)	PICTURE TUBE	
△ DY01	QQD0011-001	DEF YOKE	
△ L01	QQW0002-001	DEG COIL	
△ T1522	QQH0030-002	H.V.TRANSF.	
1	CE42153-00AJ1	WEDGE ASSY	(×4)
2	CE42378-00B	P.C.MAGNET	
3	A48457-4-S	SPRING	
4	CHGB0016-0H	BRAIDED ASSY	
5	LC30191-001C-A	LENS	
6	LC30376-002A-A	POWER KNOB	
7	LC30271-002A-A	PUSH KNOB	
△ 8	CEBSS09D-03KJ2	SPEAKER	(×2)SP01,SP02
9	CM48144-001-A	PB STOPPER	
△ 10	LC10108-003D-A	REAR COVER	
△ 11	QMPD209-200-JC	POWER CORD	CN10PW (Within MAIN PWB)
△ 12	LC20106-002C-A	POWER CORD CLAMP	
13	QYSB5FG4016Z	TAPPING SCREW	(×5)
14	QYSBSB3010Z	TAPPING SCREW	(×2)
△ 15	LC31139-001A-A	RATING LABEL	
△ 16	LC10109-017A-A	FRONT CABINET	
17	CM43094-006-H	JVC MARK	

# EXPLODED VIEW

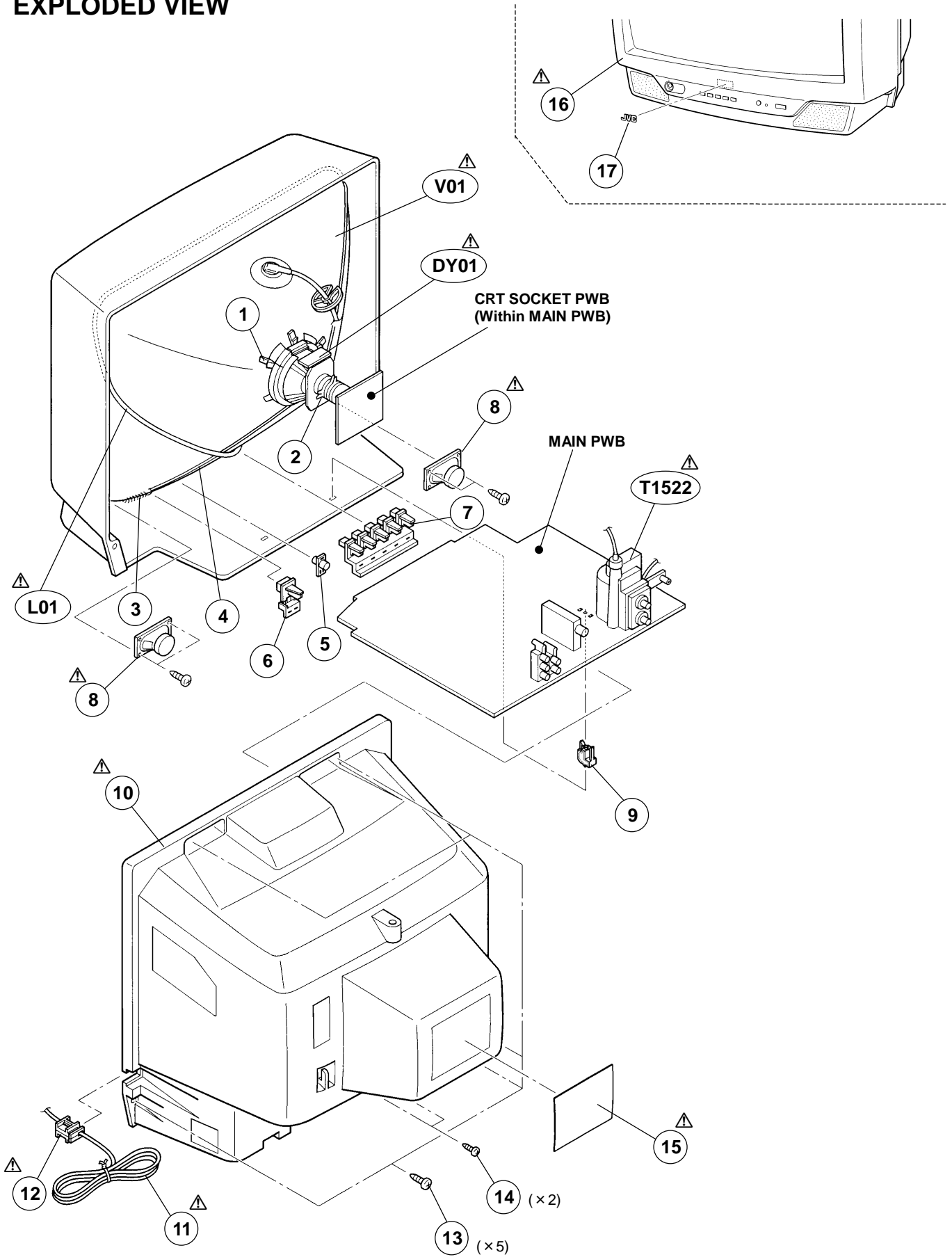

# PRINTED WIRING BOARD PARTS LIST

## MAIN P.W. BOARD ASS'Y (SFV-1063A-M2) [AV-20220/s]

△ Symbol No.	Part No.	Part Name	Description
<b>RESISTOR</b>			
R1003-04	NRSA02J-0ROX	MG R	0.0Ω 1/10W J
R1101	NRSA02J-820X	MG R	82Ω 1/10W J
R1102	NRSA02J-562X	MG R	5.6kΩ 1/10W J
R1103	NRSA02J-182X	MG R	1.8kΩ 1/10W J
R1104	QRE121J-101Y	C R	100Ω 1/2W J
R1105	NRSA02J-180X	MG R	18Ω 1/10W J
R1106	NRSA02J-270X	MG R	27Ω 1/10W J
R1131	NRSA02J-271X	MG R	270Ω 1/10W J
R1133	NRSA02J-101X	MG R	100Ω 1/10W J
R1134	NRSA02J-102X	MG R	1kΩ 1/10W J
R1135	NRSA02J-561X	MG R	560Ω 1/10W J
R1136	NRSA02J-821X	MG R	820Ω 1/10W J
R1137	NRSA02J-152X	MG R	1.5kΩ 1/10W J
R1138	NRSA02J-821X	MG R	820Ω 1/10W J
R1139	NRSA02J-0ROX	MG R	0.0Ω 1/10W J
R1142	NRSA02J-101X	MG R	100Ω 1/10W J
R1145	NRSA02J-472X	MG R	4.7kΩ 1/10W J
R1146	NRSA02J-562X	MG R	5.6kΩ 1/10W J
R1161-62	NRSA02J-102X	MG R	1kΩ 1/10W J
R1163	NRSA02J-472X	MG R	4.7kΩ 1/10W J
R1164	NRSA02J-332X	MG R	3.3kΩ 1/10W J
R1165	NRSA02J-0ROX	MG R	0.0Ω 1/10W J
R1201	NRSA02J-0ROX	MG R	0.0Ω 1/10W J
R1204	NRSA02J-0ROX	MG R	0.0Ω 1/10W J
R1205	NRSA02J-152X	MG R	1.5kΩ 1/10W J
R1207	NRSA02J-0ROX	MG R	0.0Ω 1/10W J
R1208	NRSA02J-472X	MG R	4.7kΩ 1/10W J
R1209	NRSA02J-471X	MG R	470Ω 1/10W J
R1210	NRSA02J-392X	MG R	3.9kΩ 1/10W J
R1211	NRSA02J-471X	MG R	470Ω 1/10W J
R1212	NRSA02J-103X	MG R	10kΩ 1/10W J
R1213	NRSA02J-391X	MG R	390Ω 1/10W J
R1215	NRSA02J-334X	MG R	330kΩ 1/10W J
R1216	NRSA02J-563X	MG R	56kΩ 1/10W J
R1218	NRSA02J-182X	MG R	1.8kΩ 1/10W J
R1219	NRSA02J-122X	MG R	1.2kΩ 1/10W J
R1251	NRSA02J-750X	MG R	75Ω 1/10W J
R1255	NRSA02J-750X	MG R	75Ω 1/10W J
R1264	NRSA02J-222X	MG R	2.2kΩ 1/10W J
R1265	NRSA02J-0ROX	MG R	0.0Ω 1/10W J
R1266	NRSA02J-152X	MG R	1.5kΩ 1/10W J
R1267	NRSA02J-0ROX	MG R	0.0Ω 1/10W J
R1271-72	NRSA02J-102X	MG R	1kΩ 1/10W J
R1278	NRSA02J-152X	MG R	1.5kΩ 1/10W J
R1290	NRSA02J-563X	MG R	56kΩ 1/10W J
R1291	NRSA02J-473X	MG R	47kΩ 1/10W J
R1298-99	NRSA02J-0ROX	MG R	0.0Ω 1/10W J
R1305	NRSA02J-393X	MG R	39kΩ 1/10W J
R1306	NRSA02J-183X	MG R	18kΩ 1/10W J
R1351	NRSA02J-152X	MG R	1.5kΩ 1/10W J
R1352	NRSA02J-102X	MG R	1kΩ 1/10W J
R1354	NRSA02J-272X	MG R	2.7kΩ 1/10W J
R1365	NRSA02J-152X	MG R	1.5kΩ 1/10W J
R1366	NRSA02J-563X	MG R	56kΩ 1/10W J
R1367	NRSA02J-333X	MG R	33kΩ 1/10W J
R1371-73	NRSA02J-151X	MG R	150Ω 1/10W J
R1374-76	NRSA02J-331X	MG R	330Ω 1/10W J
R1377-79	NRSA02J-101X	MG R	100Ω 1/10W J
R1380-82	QRZ0111-152	C R	1.5kΩ 1/2W K
R1383-85	QRL029J-123	OM R	12kΩ 2W J
R1386-88	NRSA02J-272X	MG R	2.7kΩ 1/10W J
R1421	NRSA02J-472X	MG R	4.7kΩ 1/10W J
R1422	QRE121J-391Y	C R	390Ω 1/2W J
R1423	QRX016J-1R5	MF R	1.5Ω 1W J
R1425	NRSA02J-683X	MG R	68kΩ 1/10W J
R1427	NRSA02J-392X	MG R	3.9kΩ 1/10W J
R1428	NRSA02J-393X	MG R	39kΩ 1/10W J
R1429	NRSA02J-223X	MG R	22kΩ 1/10W J
R1430-31	NRSA02J-0ROX	MG R	0.0Ω 1/10W J
R1441	QRE121J-102Y	C R	1kΩ 1/2W J

△ Symbol No.	Part No.	Part Name	Description
<b>RESISTOR</b>			
R1501	NRSA02J-361X	MG R	360Ω 1/10W J
R1502	NRSA02J-152X	MG R	1.5kΩ 1/10W J
R1504	NRSA02J-0ROX	MG R	0.0Ω 1/10W J
R1505	NRSA02J-822X	MG R	8.2kΩ 1/10W J
R1506	NRSA02J-222X	MG R	2.2kΩ 1/10W J
R1507	NRSA02J-563X	MG R	56kΩ 1/10W J
R1511	QRE121J-391Y	C R	390Ω 1/2W J
R1521	QRE121J-220Y	C R	22Ω 1/2W J
R1522	NRSA02J-391X	MG R	390Ω 1/10W J
R1523	NRSA02J-471X	MG R	470Ω 1/10W J
R1524	QRE121J-271Y	C R	270Ω 1/2W J
R1525	QRL029J-121	OM R	120Ω 2W J
R1526	QRL039J-152	OM R	1.5kΩ 3W J
R1541	QRT029J-1R8	MF R	1.8Ω 2W J
R1542	QRL029J-101	OM R	100Ω 2W J
R1543	QRT039J-1R0	MF R	1.0Ω 3W J
R1544	QRT039J-2R2	MF R	2.2Ω 3W J
R1546	QRL029J-220	OM R	22Ω 2W J
R1561	QRK126J-4R7X	C R	4.7Ω 1/2W J
△ R1562	NRZ0032-7151X	MF R	7.15kΩ 1/10W J
△ R1563	NRZ0032-3241X	MF R	3.24kΩ 1/10W J
R1564	NRSA02J-153X	MG R	15kΩ 1/10W J
R1565	NRSA02J-0ROX	MG R	0.0Ω 1/10W J
R1566	NRSA02J-333X	MG R	33kΩ 1/10W J
R1567	NRSA02J-392X	MG R	3.9kΩ 1/10W J
R1568	NRSA02J-223X	MG R	22kΩ 1/10W J
R1571	QRX016J-1R2	MF R	1.2Ω 1W J
R1581	QRJ146J-2R2X	C R	2.2Ω 1/4W J
R1582	QRL029J-223	OM R	22kΩ 2W J
R1583	QRE121J-333Y	C R	33kΩ 1/2W J
R1584	QRE121J-393Y	C R	39kΩ 1/2W J
R1585	QRE121J-103Y	C R	10kΩ 1/2W J
R1586	QRE121J-472Y	C R	4.7kΩ 1/2W J
R1615-16	NRSA02J-123X	MG R	12kΩ 1/10W J
R1617-18	NRSA02J-332X	MG R	3.3kΩ 1/10W J
R1619-20	NRSA02J-561X	MG R	560Ω 1/10W J
R1621-22	QRE121J-4R7Y	C R	4.7Ω 1/2W J
R1623	NRSA02J-0ROX	MG R	0.0Ω 1/10W J
R1625	NRSA02J-333X	MG R	33kΩ 1/10W J
R1627	NRSA02J-101X	MG R	100Ω 1/10W J
R1628-29	QRE121J-271Y	C R	270Ω 1/2W J
R1651	NRSA02J-102X	MG R	1kΩ 1/10W J
R1652-53	NRSA02J-682X	MG R	6.8kΩ 1/10W J
R1654	NRSA02J-333X	MG R	33kΩ 1/10W J
R1655	NRSA02J-332X	MG R	3.3kΩ 1/10W J
R1656	NRVA02D-152X	MF R	1.5kΩ 1/10W D
R1658	NRVA02D-153X	MF R	15kΩ 1/10W D
R1660	NRSA02J-512X	MG R	5.1kΩ 1/10W J
R1661	NRSA02J-473X	MG R	47kΩ 1/10W J
R1662-65	NRSA02J-123X	MG R	12kΩ 1/10W J
R1666-67	NRSA02J-562X	MG R	5.6kΩ 1/10W J
R1668	NRSA02J-473X	MG R	47kΩ 1/10W J
R1669-70	NRSA02J-471X	MG R	470Ω 1/10W J
R1671-72	NRSA02J-102X	MG R	1kΩ 1/10W J
R1673-74	NRSA02J-823X	MG R	82kΩ 1/10W J
R1675-76	NRSA02J-181X	MG R	180Ω 1/10W J
R1677	NRSA02J-0ROX	MG R	0.0Ω 1/10W J
R1678-81	NRSA02J-223X	MG R	22kΩ 1/10W J
R1682	NRSA02J-683X	MG R	68kΩ 1/10W J
R1683-84	NRSA02J-561X	MG R	560Ω 1/10W J
R1685-86	NRSA02J-0ROX	MG R	0.0Ω 1/10W J
R1687-88	NRSA02J-102X	MG R	1kΩ 1/10W J
R1691	NRSA02J-563X	MG R	56kΩ 1/10W J
R1701	NRSA02J-563X	MG R	56kΩ 1/10W J
R1702	NRSA02J-103X	MG R	10kΩ 1/10W J
R1703	NRSA02J-0ROX	MG R	0.0Ω 1/10W J
R1704	NRSA02J-103X	MG R	10kΩ 1/10W J
R1705	NRSA02J-823X	MG R	82kΩ 1/10W J
R1706	NRSA02J-103X	MG R	10kΩ 1/10W J
R1707	NRSA02J-0ROX	MG R	0.0Ω 1/10W J

Symbol No.	Part No.	Part Name	Description	Symbol No.	Part No.	Part Name	Description
<b>RESISTOR</b>				<b>CAPACITOR</b>			
R1708-09	NRSA02J-103X	MG R	10kΩ 1/10W J	C1105	QETN1CM-107Z	E CAP.	100μF 16V M
R1710	NRSA02J-102X	MG R	1kΩ 1/10W J	C1106	NCB21HK-103X	C CAP.	0.01μF 50V K
R1712	NRSA02J-0R0X	MG R	0.0Ω 1/10W J	C1107	NRSA02J-0R0X	MG R	0.0Ω 1/10W J
R1713	NRSA02J-102X	MG R	1kΩ 1/10W J	C1108	NDC21HJ-680X	C CAP.	68pF 50V J
R1714	NRSA02J-471X	MG R	470Ω 1/10W J	C1131	QFV71HJ-154Z	MF CAP.	0.15μF 50V J
R1715	NRSA02J-105X	MG R	1MΩ 1/10W J	C1132	NCB21HK-152X	C CAP.	1500pF 50V K
R1716	NRSA02J-154X	MG R	150kΩ 1/10W J	C1133	QETN1HM-474Z	E CAP.	0.47μF 50V M
R1717	NRSA02J-563X	MG R	56kΩ 1/10W J	C1134	NCB21HK-472X	C CAP.	4700pF 50V K
R1719	NRSA02J-102X	MG R	1kΩ 1/10W J	C1135	NCB21HK-103X	C CAP.	0.01μF 50V K
R1721-22	NRSA02J-0R0X	MG R	0.0Ω 1/10W J	C1138	QETN1EM-476Z	E CAP.	47μF 25V M
R1723	NRSA02J-105X	MG R	1MΩ 1/10W J	C1161	QETN1CM-107Z	E CAP.	100μF 16V M
R1724	NRSA02J-102X	MG R	1kΩ 1/10W J	C1162	NCB21HK-103X	C CAP.	0.01μF 50V K
R1725	NRSA02J-103X	MG R	10kΩ 1/10W J	C1163-64	NDC21HJ-470X	C CAP.	47pF 50V J
R1726	NRSA02J-392X	MG R	3.9kΩ 1/10W J	C1166	NCB21HK-103X	C CAP.	0.01μF 50V K
R1727	NRSA02J-103X	MG R	10kΩ 1/10W J	C1167	NDC21HJ-470X	C CAP.	47pF 50V J
R1728	NRSA02J-392X	MG R	3.9kΩ 1/10W J	C1169-70	NCB21HK-103X	C CAP.	0.01μF 50V K
R1729	NRSA02J-153X	MG R	15kΩ 1/10W J	C1207	QETN1HM-474Z	E CAP.	0.47μF 50V M
R1730	NRSA02J-682X	MG R	6.8kΩ 1/10W J	C1208	QETN1HM-106Z	E CAP.	10μF 50V M
R1731	NRSA02J-0R0X	MG R	0.0Ω 1/10W J	C1209-10	QETN1HM-105Z	E CAP.	1μF 50V M
R1732	NRSA02J-102X	MG R	1kΩ 1/10W J	C1212	NCB21HK-104X	CHIP CAP.	0.1μF 50V K
R1734	NRSA02J-182X	MG R	1.8kΩ 1/10W J	C1214	QETN1HM-106Z	E CAP.	10μF 50V M
R1735	NRSA02J-102X	MG R	1kΩ 1/10W J	C1215	QETN1HM-105Z	E CAP.	1μF 50V M
R1736	NRSA02J-332X	MG R	3.3kΩ 1/10W J	C1217	QETN1EM-476Z	E CAP.	47μF 25V M
R1737	NRSA02J-472X	MG R	4.7kΩ 1/10W J	C1252	QETN1HM-106Z	E CAP.	10μF 50V M
R1738	NRSA02J-152X	MG R	1.5kΩ 1/10W J	C1254-55	QETN1HM-106Z	E CAP.	10μF 50V M
R1739	NRSA02J-472X	MG R	4.7kΩ 1/10W J	C1274	QETN1HM-105Z	E CAP.	1μF 50V M
R1740	NRSA02J-152X	MG R	1.5kΩ 1/10W J	C1303	NCB21HK-103X	C CAP.	0.01μF 50V K
R1741	NRSA02J-472X	MG R	4.7kΩ 1/10W J	C1304	QETN1CM-107Z	E CAP.	100μF 16V M
R1742	NRSA02J-152X	MG R	1.5kΩ 1/10W J	C1305	NDC21HJ-100X	C CAP.	10pF 50V J
R1743-44	NRSA02J-0R0X	MG R	0.0Ω 1/10W J	C1306	NCB21HK-223X	C CAP.	0.022μF 50V K
R1745-46	NRSA02J-561X	MG R	560Ω 1/10W J	C1307	QETN1HM-474Z	E CAP.	0.47μF 50V M
R1747	NRSA02J-0R0X	MG R	0.0Ω 1/10W J	C1309	NDC21HJ-2R0X	C CAP.	2.0pF 50V J
R1751	NRSA02J-103X	MG R	10kΩ 1/10W J	C1352	NDC21HJ-680X	C CAP.	68pF 50V J
R1752	NRSA02J-472X	MG R	4.7kΩ 1/10W J	C1353	NRSA02J-0R0X	MG R	0.0Ω 1/10W J
R1753	NRSA02J-153X	MG R	15kΩ 1/10W J	C1355	NDC21HJ-150X	C CAP.	15pF 50V J
R1754	NRSA02J-103X	MG R	10kΩ 1/10W J	C1356	NCB21HK-103X	C CAP.	0.01μF 50V K
R1755	NRSA02J-472X	MG R	4.7kΩ 1/10W J	C1374-75	NCS21HJ-271X	C CAP.	270pF 50V J
R1756	NRSA02J-153X	MG R	15kΩ 1/10W J	C1376	NCS21HJ-331X	C CAP.	330pF 50V J
R1757-58	NRSA02J-122X	MG R	1.2kΩ 1/10W J	C1377	QETN1CM-107Z	E CAP.	100μF 16V M
R1759	NRSA02J-0R0X	MG R	0.0Ω 1/10W J	C1391	QETM2EM-336	E CAP.	33μF 250V M
R1765-66	NRSA02J-0R0X	MG R	0.0Ω 1/10W J	△ C1392	QCZ0121-102	C CAP.	1000pF 3kV Z
R1767	NRSA02J-474X	MG R	470kΩ 1/10W J	C1401	QETN1HM-225Z	E CAP.	2.2μF 50V M
R1768	NRSA02J-473X	MG R	47kΩ 1/10W J	C1402	QBHC1CK-225Z	TAN. CAP.	2.2μF 16V K
R1769	NRSA02J-102X	MG R	1kΩ 1/10W J	C1403	NCB21HK-102X	C CAP.	1000pF 50V K
R1771	NRSA02J-0R0X	MG R	0.0Ω 1/10W J	C1421	NCB21HK-103X	C CAP.	0.01μF 50V K
R1804-06	NRSA02J-101X	MG R	100Ω 1/10W J	C1422	QCS32HJ-560Z	C CAP.	560pF 500V J
△ R1901	QRF054K-1R0	UNF R	1.0 Ω 5W K	C1423	QCS32HJ-180Z	C CAP.	18pF 500V J
△ R1921	QRX029J-2R7	MF R	2.7 Ω 2W J	C1424	QETN1VM-107Z	E CAP.	100μF 35V M
R1923	QRJ146J-470X	C R	47Ω 1/4W J	C1425	QETN1VM-477Z	E CAP.	470μF 35V M
R1924	QRN141J-334Y	C R	330kΩ 1/4W J	C1426	QFLC2AK-104Z	M CAP.	0.1μF 100V K
R1925	QRN141J-123Y	C R	12kΩ 1/4W J	C1427	QETM1EM-228	E CAP.	2200μF 25V M
△ R1926	QRF154J-271	UNF R	270 Ω 15W J	C1428	QFV21HJ-474Z	MF CAP.	0.47μF 50V J
R1952	NRSA02J-222X	MG R	2.2kΩ 1/10W J	C1429	QFV21HJ-224Z	MF CAP.	0.22μF 50V J
R1953	NRSA02J-122X	MG R	1.2kΩ 1/10W J	C1501	QETN1CM-107Z	E CAP.	100μF 16V M
R1954	QRE121J-102Y	C R	1kΩ 1/2W J	C1502	QETN1HM-106Z	E CAP.	10μF 50V M
R1955	NRSA02J-223X	MG R	22kΩ 1/10W J	C1503	NCB21HK-103X	C CAP.	0.01μF 50V K
R1956	QRE121J-101Y	C R	100Ω 1/2W J	C1505	QETN1HM-106Z	E CAP.	10μF 50V M
R1957	NRSA02J-222X	MG R	2.2kΩ 1/10W J	C1511	QETN1EM-476Z	E CAP.	47μF 25V M
R1958	NRSA02J-103X	MG R	10kΩ 1/10W J	C1521	NCB21HK-332X	C CAP.	3300pF 50V K
△ R1981	QRZ9041-275	C R	2.7M 1/2W K	C1522	NCB21HK-822X	C CAP.	8200pF 50V K
<b>CAPACITOR</b>				C1523	QEM61HK-105Z	E CAP.	1μF 50V K
C1001	QETN1HM-106Z	E CAP.	10μF 50V M	△ C1524	QFZ0198-79Z	MPP CAP.	7900pF 1.4kVH±2.5%
C1003	QETN1AM-477Z	E CAP.	470μF 10V M	C1525	QEZ0203-107	E CAP.	100μF 160V M
C1004	QETN1HM-106Z	E CAP.	10μF 50V M	△ C1526	QFZ0119-534	MPP CAP.	0.53μF 200V ±3%
C1005	NCB21HK-103X	C CAP.	0.01μF 50V K	C1543	QETN1VM-477Z	E CAP.	470μF 35V M
C1006	QETN1EM-476Z	E CAP.	47μF 25V M	C1545	QETN1CM-227Z	E CAP.	220μF 16V M
C1011-12	NCB21HK-102X	C CAP.	1000pF 50V K	C1546	QETN1CM-477Z	E CAP.	470μF 16V M
C1013	NCB21HK-104X	CHIP CAP.	0.1μF 50V K	C1548	QETN1CM-227Z	E CAP.	220μF 16V M
C1101-04	NCB21HK-103X	C CAP.	0.01μF 50V K	△ C1561	QETN1HM-106Z	E CAP.	10μF 50V M
				C1562	QETN1HM-475Z	E CAP.	4.7μF 50V M
				C1563	NCB21HK-103X	C CAP.	0.01μF 50V K
				△ C1581	QETN2EM-106Z	E CAP.	10μF 250V M



△ Symbol No.	Part No.	Part Name	Description
<b>CAPACITOR</b>			
C1582	NCB21HK-473X	C CAP.	0.047µF 50V K
C1583	QETN1HM-106Z	E CAP.	10µF 50V M
C1584	QFLC2AJ-104Z	M CAP.	0.1µF 100V J
C1615	NRSA02J-0R0X	MG R	0.0Ω 1/10W J
C1616	QENC1HM-474Z	BP E CAP.	0.47µF 50V M
C1617	QETN1EM-476Z	E CAP.	47µF 25V M
C1618	QETN1CM-107Z	E CAP.	100µF 16V M
C1619	QETN1CM-477Z	E CAP.	470µF 16V M
C1620	NCB21HK-104X	CHIP CAP.	0.1µF 50V K
C1621	NRSA02J-0R0X	MG R	0.0Ω 1/10W J
C1622	QENC1HM-474Z	BP E CAP.	0.47µF 50V M
C1623	QETN1EM-476Z	E CAP.	47µF 25V M
C1624	QETN1CM-107Z	E CAP.	100µF 16V M
C1625	QETN1CM-477Z	E CAP.	470µF 16V M
C1626	NCB21HK-104X	CHIP CAP.	0.1µF 50V K
C1627	QETN1CM-477Z	E CAP.	470µF 16V M
C1651	NCB21HK-103X	C CAP.	0.01µF 50V K
C1652	QETN1CM-107Z	E CAP.	100µF 16V M
C1653	QETN1EM-476Z	E CAP.	47µF 25V M
C1654	NCB21HK-104X	CHIP CAP.	0.1µF 50V K
C1655	QENC1HM-475Z	BP E CAP.	4.7µF 50V M
C1656	QENC1HM-105Z	BP E CAP.	1µF 50V M
C1657	QETN1HM-225Z	E CAP.	2.2µF 50V M
C1658	NCB21HK-473X	C CAP.	0.047µF 50V K
C1659	QETN1HM-474Z	E CAP.	0.47µF 50V M
C1660-61	NCB21HK-104X	CHIP CAP.	0.1µF 50V K
C1662	QBTC1CK-335Z	TAN. CAP.	3.3µF 16V K
C1663	QETN1HM-105Z	E CAP.	1µF 50V M
C1664	QBTC1CK-106Z	TAN. CAP.	10µF 16V K
C1665-66	QETN1HM-105Z	E CAP.	1µF 50V M
C1667	QETN1HM-336Z	E CAP.	33µF 50V M
C1668	QETN1HM-105Z	E CAP.	1µF 50V M
C1669-70	QENC1HM-105Z	BP E CAP.	1µF 50V M
C1671	QETN1HM-225Z	E CAP.	2.2µF 50V M
C1672	NCB21HK-222X	C CAP.	2200pF 50V K
C1673	NCB21HK-104X	CHIP CAP.	0.1µF 50V K
C1674	QETN1HM-225Z	E CAP.	2.2µF 50V M
C1675	NCB21HK-222X	C CAP.	2200pF 50V K
C1676	NCB21HK-104X	CHIP CAP.	0.1µF 50V K
C1679	QETN1HM-105Z	E CAP.	1µF 50V M
C1680	QETN1EM-476Z	E CAP.	47µF 25V M
C1682-83	QETN1HM-474Z	E CAP.	0.47µF 50V M
C1685-86	QETN1HM-106Z	E CAP.	10µF 50V M
C1687-88	NCB21HK-472X	C CAP.	4700pF 50V K
C1689-90	QETN1HM-106Z	E CAP.	10µF 50V M
C1702	NCB21HK-272X	C CAP.	2700pF 50V K
C1704	NCB21HK-103X	C CAP.	0.01µF 50V K
C1705	NDC21HJ-151X	C CAP.	150pF 50V J
C1706	NCB21HK-104X	CHIP CAP.	0.1µF 50V K
C1707	QETN1HM-105Z	E CAP.	1µF 50V M
C1708	NCS21HJ-221X	C CAP.	220pF 50V J
C1709	NCS21HJ-102X	C CAP.	1000pF 50V J
C1710	NDC21HJ-681X	C CAP.	680pF 50V J
C1711	QETN1HM-474Z	E CAP.	0.47µF 50V M
C1712	NCB21HK-102X	C CAP.	1000pF 50V K
C1714	NCB21HK-103X	C CAP.	0.01µF 50V K
C1716	QETN1EM-476Z	E CAP.	47µF 25V M
C1717	NCB21HK-104X	CHIP CAP.	0.1µF 50V K
C1718	NCB21HK-103X	C CAP.	0.01µF 50V K
C1719-20	QETN1CM-107Z	E CAP.	100µF 16V M
C1721	NCB21HK-104X	CHIP CAP.	0.1µF 50V K
C1722-23	NDC21HJ-5R0X	C CAP.	5.0pF 50V J
C1724	NCB21HK-103X	C CAP.	0.01µF 50V K
C1725	QETN1AM-227Z	E CAP.	220µF 10V M
C1726	NDC21HJ-470X	C CAP.	47pF 50V J
C1735	NCB21HK-103X	C CAP.	0.01µF 50V K
C1751	QETN1EM-476Z	E CAP.	47µF 25V M
C1801-03	QENC1HM-474Z	BP E CAP.	0.47µF 50V M
△ C1901	QFZ9040-104	MF CAP.	0.1µFAC275V M
△ C1902	QFZ9040-473	MF CAP.	0.047µFAC275V M
△ C1911	QCZ9074-472	C CAP.	4700pFAC250V M
△ C1912	QCZ9074-472	C CAP.	4700pFAC250V M
△ C1913	QCZ9074-472	C CAP.	4700pFAC250V M

△ Symbol No.	Part No.	Part Name	Description
<b>CAPACITOR</b>			
△ C1914	QEZ0169-337	E CAP.	330µF 200V M
C1921	QHR2CM-335Z	E CAP.	3.3µF 160V M
C1922	QEHQ2CM-336	E CAP.	33µF 160V M
C1951	QETN1EM-227Z	E CAP.	220µF 25V M
C1953	QETN1EM-107Z	E CAP.	100µF 25V M
C1954	NCB21HK-473X	C CAP.	0.047µF 50V K
C1956	QETN1HM-106Z	E CAP.	10µF 50V M
C1958	QETN1EM-107Z	E CAP.	100µF 25V M
C1959	QETN1HM-226Z	E CAP.	22µF 50V M
△ C1981	QCZ9074-103	C CAP.	0.01µFAC250V M
△ C1982	QCZ9074-103	C CAP.	0.01µFAC250V M
<b>TRANSFORMER</b>			
T1131	QQR0907-001	I. F. TRANSFORMER	
T1161	CELT003-109J3	S. I. F. TRANSF.	
△ T1521	CE41106-00CJ1	DRIVE TRANSF.	
△ T1522	QHQ0030-002	H. V. TRANSF.	
△ T1901	QQT0198-001	POWER TRANSF.	
<b>COIL</b>			
L1003	QQL03BJ-5R6Z	PEAKING COIL	
L1102	QQLZ014-R22	PEAKING COIL	0.22µH
L1104	QQL03BJ-680Z	PEAKING COIL	
L1131	QQL03BJ-220Z	PEAKING COIL	
L1161	QQL03BJ-680Z	PEAKING COIL	
L1162	QQL03BJ-390Z	PEAKING COIL	
L1351	QQL03BJ-220Z	PEAKING COIL	
L1391	QQL03BJ-390Z	PEAKING COIL	
L1701	QQL03BJ-4R7Z	PEAKING COIL	
L1709	QQL03BJ-100Z	PEAKING COIL	
<b>DIODE</b>			
D1001	MTZJ33B-T2	ZENER DIODE	
D1003-04	MTZJ9.1C-T2	ZENER DIODE	
D1201-03	1S5133-T2	SI. DIODE	
D1251-52	MTZJ9.1C-T2	ZENER DIODE	
D1254	MTZJ9.1C-T2	ZENER DIODE	
D1421	1N4003-T2	SI. DIODE	
D1422	MTZJ75-T2	ZENER DIODE	
D1423	1S5133-T2	SI. DIODE	
D1501	MTZJ9.1C-T2	ZENER DIODE	
D1511	MTZJ3.3A-T2	ZENER DIODE	
D1541	RGP10J-5025-T3	SI. DIODE	
D1542	1SR35-400A-T2	SI. DIODE	
D1543-44	RGP10J-5025-T3	SI. DIODE	
D1561	1S581-T2	SI. DIODE	
△ D1562	MA4068N/Z1/-T2	ZENER DIODE	
D1563	1S5133-T2	SI. DIODE	
△ D1581	RH15-T3	SI. DIODE	
D1582	RGP10J-5025-T3	SI. DIODE	
D1583	MTZJ9.1C-T2	ZENER DIODE	
D1601-02	1S5133-T2	SI. DIODE	
D1651-52	MTZJ9.1C-T2	ZENER DIODE	
D1656-57	MTZJ9.1C-T2	ZENER DIODE	
D1659-60	MTZJ9.1C-T2	ZENER DIODE	
D1703	MTZJ5.6A-T2	ZENER DIODE	
D1704-07	1S5133-T2	SI. DIODE	
D1711	1S5133-T2	SI. DIODE	
D1717-18	MTZJ9.1C-T2	ZENER DIODE	
D1751	SLR-342VR3F	L. E. D.	
D1804	MTZJ5.1B-T2	ZENER DIODE	
D1805	1S5133-T2	SI. DIODE	
△ D1911	D35B60	BRIDGE DIODE	
D1941-44	1SR35-400A-T2	SI. DIODE	
D1951	MTZJ12C-T2	ZENER DIODE	
D1953	1SR35-400A-T2	SI. DIODE	
D1957-58	1S5133-T2	SI. DIODE	
<b>TRANSISTOR</b>			
Q1101	2SC5083/L-P/-T	SI. TRANSISTOR	
Q1131-32	2SC2412K/QR/-X	SI. TRANSISTOR	
Q1161	2SC2412K/QR/-X	SI. TRANSISTOR	

Symbol No.	Part No.	Part Name	Description
<b>TRANSISTOR</b>			
Q1202-03	25C2412K/QR/-X	SI. TRANSISTOR	
Q1261	25C2412K/QR/-X	SI. TRANSISTOR	
Q1271	25C2412K/QR/-X	SI. TRANSISTOR	
Q1361	25C2412K/QR/-X	SI. TRANSISTOR	
Q1371-73	25C4544-LB	SI. TRANSISTOR	
Q1521	25C2655/Y/-T	SI. TRANSISTOR	
△ Q1522	25D1878-YD	SI. TRANSISTOR	H. OUT
Q1561	25C2785/JH/-T	SI. TRANSISTOR	
Q1562	25A933AS/QR/-T	SI. TRANSISTOR	
Q1602	DTC323TK-X	DIGI. TRANSISTOR	
Q1651-54	25C2412K/QR/-X	SI. TRANSISTOR	
Q1655	25A1037AK/QR/-X	SI. TRANSISTOR	
Q1701-03	25C2412K/QR/-X	SI. TRANSISTOR	
Q1704	DTC323TK-X	DIGI. TRANSISTOR	
Q1951	25C2412K/QR/-X	SI. TRANSISTOR	
Q1952	25A966/OY/-T	SI. TRANSISTOR	
Q1953	25C2412K/QR/-X	SI. TRANSISTOR	
<b>IC</b>			
IC1001	AN7805F	I. C. (MONO-ANA)	
IC1201	TA1242N	I. C. (MONO-ANA)	
IC1251	BA7612N	I. C. (MONO-ANA)	
△ IC1421	LA7830	I. C. (MONO-ANA)	
IC1541	AN7809F	I. C. (MONO-ANA)	
△ IC1602	LA4446	I. C. (MONO-ANA)	
IC1651	UPC1851BCU	I. C. (MONO-ANA)	
IC1652	BA15218N	I. C. (MONO-ANA)	
IC1701	M37272MA-313SP	I. C. (MICRO-COMP)	
IC1702	AT24C02-20220S	I. C.	(SERVICE)
IC1703	L78LR05E-MA	I. C. (MONO-ANA)	
IC1751	GP1U281Q	IFR DETECT UNIT	
△ IC1921	STR30134	I. C. (H)	
IC1951	TA78L009AP-T	I. C. (MONO-ANA)	
<b>OTHERS</b>			
CF1001	LC30190-001B-A	LED HOLDER	
CF1131	QAX0349-001	CERAMIC FILTER	
CF1161	CE41505-001	CERAMIC FILTER	
CF1501	SFSH4.5MCB	CERAMIC FILTER	
CF1701	CSB503F30-T2	CER. RESONATOR	
CF1702	CST8.00MTW	CER. RESONATOR	
CL1001	QAX0428-001	CER. RESONATOR	
CL1002-03	QZW0028-001	WIRE CLAMP	
△ CN10PW	QMPD200-200-JC	POWER CORD	(Charcoal type)
△ F1901	QMF0007-6R3J1	FUSE	6.3A
△ F1902	QMF0007-1R25J1	FUSE	1.25A
FC1901	CEMG002-001Z	FUSE CLIP	(x2)
FC1902	CEMG002-001Z	FUSE CLIP	(x4)
△ FR1720	QRZ9017-820	F R	82 Ω 1/4W J
J1003	QNN0349-001	PIN JACK	
J1004	QNN0348-001	PIN JACK	
J1005	QNN0281-003	PIN JACK	
J1006	QNN0281-002	PIN JACK	
J1007	QNN0282-001	PIN JACK	
J1602	QNS0155-001	JACK	
K1701	QQR0582-001Z	BEADS CORE	
△ LF1901	QQR0864-002	LINE FILTER	
△ RY1901	QSK0083-001	RELAY	
S1751	QSW0619-003Z	PUSH SWITCH	MENU
S1752	QSW0619-003Z	PUSH SWITCH	CH-
S1753	QSW0619-003Z	PUSH SWITCH	CH+
S1754	QSW0619-003Z	PUSH SWITCH	VOL-
S1755	QSW0619-003Z	PUSH SWITCH	VOL+
△ S1756	QSW0619-003Z	PUSH SWITCH	POWER
SF1101	CE42589-201	SAW FILTER	
△ SK1371	CE42535-001J1	C. R. T. SOCKET	
△ TH1901	CEKP007-002	P. THERMISTOR	
△ TU1001	QAU0199-001	TUNER	
△ VA1901	ERZV10V361CS	VARIATOR	
X1301	QAX0310-001Z	CRYSTAL	

AV-20220  
AV-20221

## MAIN P.W. BOARD ASS'Y (SFV-1064A-M2) [AV-20221/S]

Regarding the parts list for the main PW board ass'y **SFV-1064A-M2**, only the different parts from those of the **SFV-1063A-M2** are described. For further details regarding the other parts, refer to the parts list for the **SFV-1063A-M2** described on page 36 through page 39.

△	Symbol No.	Parts No.		Parts Name	Description
		AV-20220/s SFV-1063A-M2	AV-20221/s SFV-1064A-M2		
△	CN10PW	QMPD200-200-JC (Charcoal type)	QMPD209-200-JC (White type)	POWER CORD	

## REMOTE CONTROL UNIT PARTS LIST(RM-C307-1A/RM-C307W-1A)

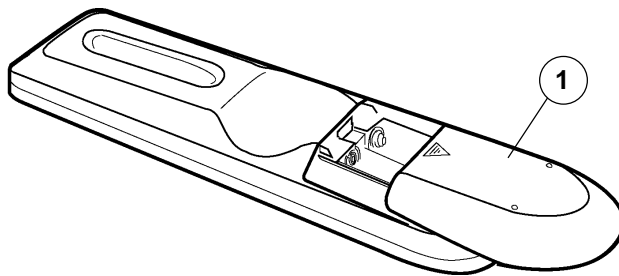

### AV-20220/S Charcoal Model

△ Ref.No.	Part No.	Part Name.	Description
1	UR52EC1286A	BATTERY COVER	(RM-C307-1A)

### AV-20221/S White Model

1	UR52EC1286B	BATTERY COVER	(RM-C307W-1A)
---	-------------	---------------	---------------

## PACKING

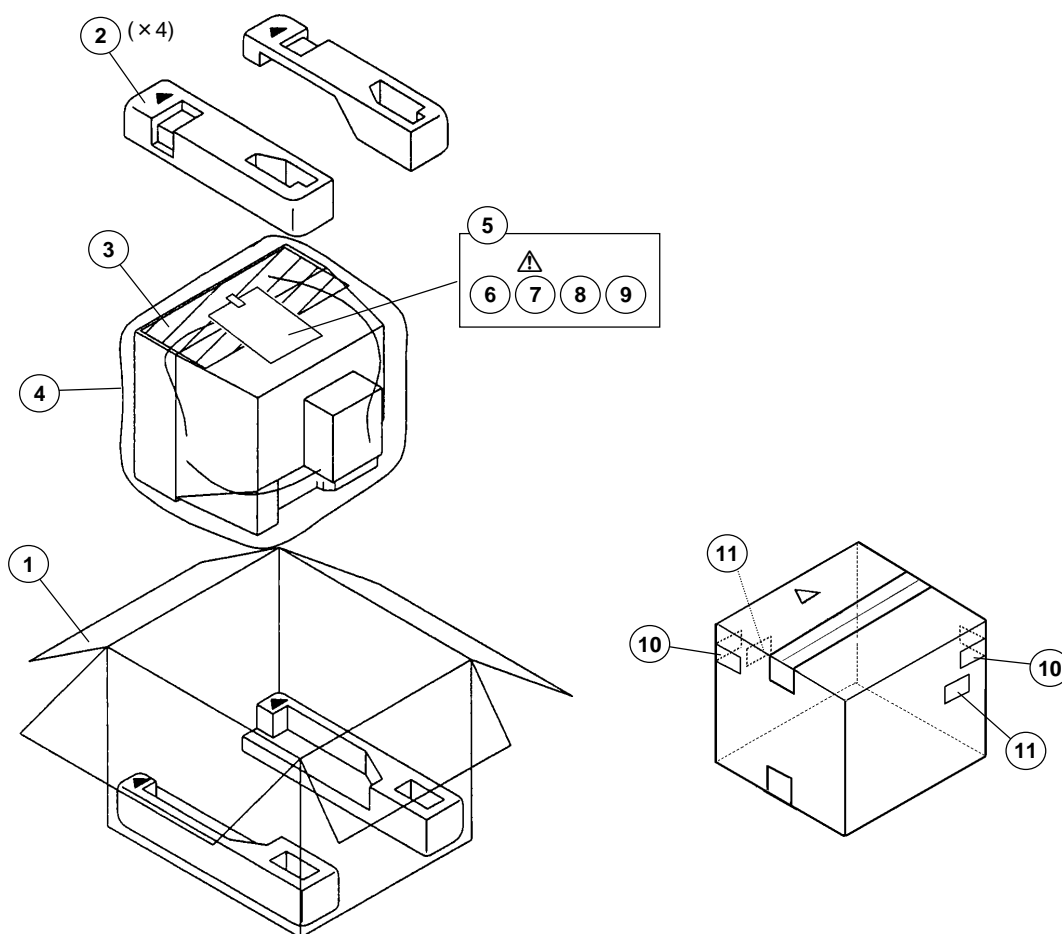

## PACKING PARTS LIST

AV-20220/S Charcoal Model				
△ Ref.No.	Part No.	Part Name	Description	
1	GQ10009-009A-A	PACKING CASE	4pcs in 1set	
2	LC10116-002A-A	CUSHION ASSY		
3	CP30055-001-A	TOP COVER		
4	CP30056-009-A	POLY BAG		
5	QPA02503505	POLY BAG		
6	RM-C307-1A	REMOCON UNIT	<b>[CHARCOAL TYPE]</b>	
△ 7	LCT0948-001A-A	INST.BOOK		
8	BT-51020-1Q	REGISTER CARD		
9	BT-52004-1Q	WARRANTY CARD	2pcs in 1set	
10	CM36616-001-A	CORNER LABEL		
AV-20221/S White Model				
1	GQ10009-009A-A	PACKING CASE	4pcs in 1set	
2	LC10116-002A-A	CUSHION ASSY		
3	CP30055-001-A	TOP COVER		
4	CP30056-009-A	POLY BAG		
5	QPA02503505	POLY BAG		
6	RM-C307W-1A	REMOCON UNIT	<b>[WHITE TYPE]</b>	
△ 7	LCT0948-001A-A	INST.BOOK		
8	BT-51020-1Q	REGISTER CARD		
9	BT-52004-1Q	WARRANTY CARD	2pcs in 1set (×2)	
10	CM36616-001-A	CORNER LABEL		
11	GQ40012-001A-A	WHITE MARK		

AV-20220  
AV-20221

